

BOXBORO systems

HARDWARE USER MANUAL Second Generation RibEye™ Model #60005 for the WorldSID 50th Male ATD

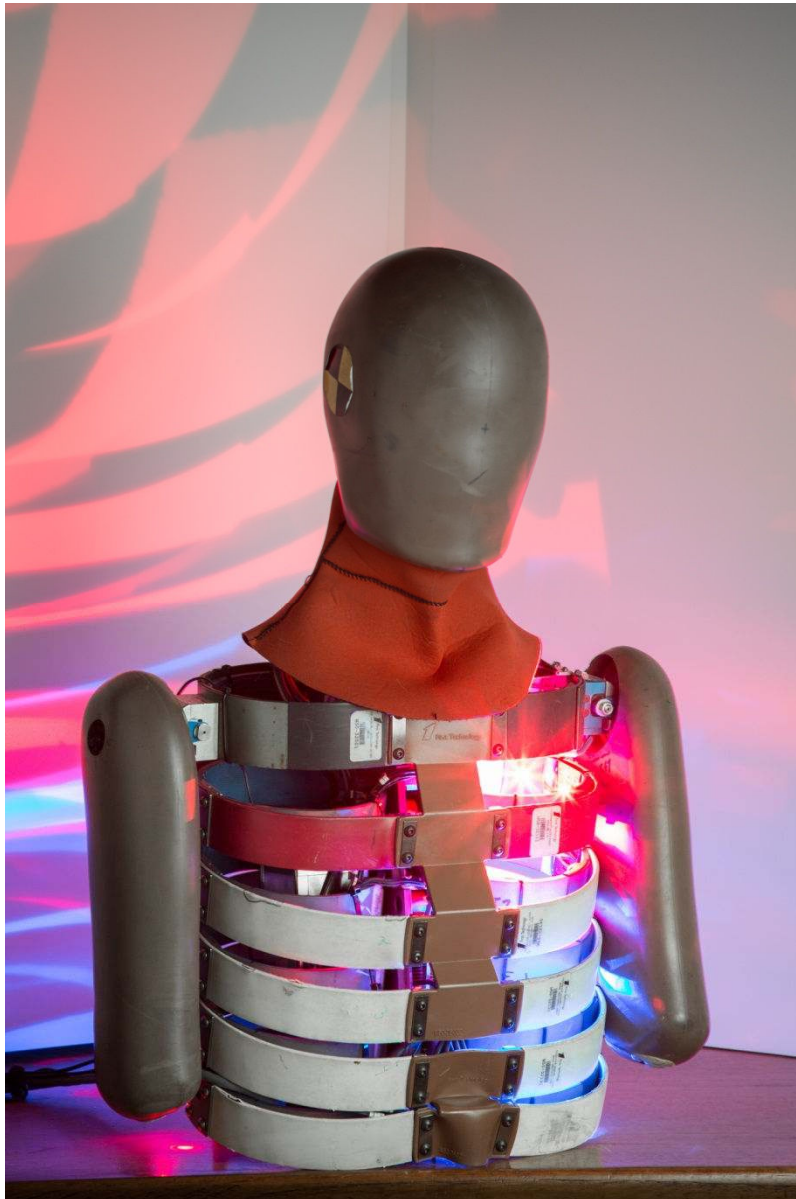

Boxboro Systems LLC
978-257-2219
www.boxborosystems.com

Table of Contents

	<u>Page</u>
1.0 WorldSID RibEye Description	6
2.0 RibEye Installation	9
2.1 LED installation on the ribs	10
2.1.1 LED assemblies	11
2.1.2 Mounting rearward LEDs on the ribs	18
2.1.3 Mounting center and forward LEDs on the ribs	21
2.1.4 Alternative method for mounting LEDs on the ribs	21
2.2 Installation of ribs and sensor assemblies on the spine	22
2.2.1 Installation of sensor bases on spine with mounting screws	22
2.2.2 Mounting sensor front pieces to sensor bases	24
2.2.3 Installation of ribs on spine and routing LED cables	26
2.3 Installing components and quick-testing RibEye operation	30
2.3.1 Mount the controller feet, battery base, and shoulder inner rib clamp	30
2.3.2 Install the LED breakout cable	32
2.3.3 Install the controller mounting plate and controller	34
2.3.4 Connect cables to controller and install battery	34
2.3.5 Verify operation via quick test prior to completing ATD assembly	37
2.4 Install mass blocks at bottom of thorax	38
2.5 Install shoulder pads	39
3.0 RibEye Operation	40
3.1 Data coordinate system	40
3.2 Status indicator	41
3.3 Ethernet link and activity lights	41
3.4 Batteries and charger	41
3.5 Error codes	43
4.0 RibEye Maintenance	45
4.1 Dummy maintenance for RibEye	45
Appendixes	
A. RibEye specifications	46
A-1. Measurement accuracy and range	46
A-2. Power requirements	50
A-3. Data acquisition and storage	50
A-4. Ethernet communication	50
A-5. Trigger circuits	51
A-6. Armed-out circuit	51
B. Cable assemblies for connection to various DAS Systems	57

Table of Contents, continued

	<u>Page</u>
C. RibEye cable connector details	61
C-1. LED cables.....	61
C-2. LED breakout cable #70030.....	62
C-3. Exit cable connector.....	63
C-4. Sensor cable connector.....	64

List of Figures

<u>Figure No.</u>		<u>Page</u>
1	RibEye sensors mounted in the dummy	6
2	RibEye LEDs mounted in the dummy.....	7
3	RibEye controller with connector end covers in place	8
4	Controller sensor connectors	8
5	Controller connectors for LED breakout cable, status cable, battery cable, and dummy exit cable.....	8
6	Battery pack and the adaptor for mounting the battery pack at the shoulder rib.....	9
7	LED positions on each rib	11
8	LED and angled mounting block.....	12
9	LED snapped into angled mounting block	12
10	Shoulder center LED adaptor plate, inner rib clamp, pin for shoulder pad, and wire clamps.....	13
11	Inner rib clamp plate for thoracic and abdominal ribs.....	14
12	Thoracic 1 inner rib clamp plate with LED and wire clamps installed	14
13	Abdominal 1 inner rib clamp plate with LED and wire clamps installed	15
14	Thoracic 2, thoracic 3, and abdominal 2 inner rib clamp plate with LEDs and wire clamps installed.....	15
15	LED cables #70031 and #70032.....	16
16	Rearward and forward LED locations.....	16
17	LED placement fixture #70300	17
18	Rearward LED placed on double-stick tape.....	18
19	Heat-shrink tubing placed over rearward LED	19
20	Cable routing for rearward and center LEDs	20
21	Alternative mounting of rearward and forward LEDs.....	21
22	M5 x 10 flat-head cap screw with precision-machined shoulder	22
23	Sensor base with label	23
24	RibEye sensor bases mounted to spine.....	23
25	RibEye sensor front piece.....	24
26	RibEye sensor label on back and alignment pins	25
27	RibEye sensor assemblies mounted to spine	26
28	Lower three ribs – abdominal 2, abdominal 1, and thoracic 3 – and RibEye sensor assemblies mounted to spine	27
29	Upper three ribs – thoracic 2, thoracic 1, and shoulder – and RibEye sensor assemblies mounted to spine	28

List of Figures, continued

<u>Figure No.</u>		<u>Page</u>
30	Right-side impact sensor cable routing	28
31	LED cables exiting the top of ribs abdominal 2 through thoracic 2 and the bottom of thoracic 1 and abdominal 1	29
32	LED routed to non-struck side	29
33	Controller foot installed on thoracic 1 rib	30
34	Controller foot installed on abdominal 2 rib	31
35	Battery base installed on shoulder rib	31
36	Shoulder inner rib clamp and shoulder foam pin installed	32
37	LED cables plugged into #70030 breakout cable	32
38	LED breakout cable – view from pelvis with LED cables plugged in	33
39	LED breakout cable – view from head with LED cables plugged in	33
40	Controller mounting plate bolted to the controller feet	34
41	Controller attached to controller mounting plate	34
42	Battery box attached to battery mount at shoulder	35
43	Connector panel at bottom of controller	36
44	Mass blocks #60416 installed at bottom of thorax	38
45	Top and bottom views of the shoulder pad assembly	39
46	RibEye coordinate system	40
47	Battery pack and adaptor	41
48	RibEye battery pack Cell-Con charger and battery cable charger receptacle	42
49	Plot overlay verifying whether LED moved out of range	44
A1	RibEye measurement range in X-Y plane – all ribs	47
A2	RibEye measurement range in Y-Z plane – upper three ribs	48
A3	RibEye measurement range in Y-Z plane – lower three ribs	49
A4	Trigger input circuits	52
A5	Trigger input configured for DTS MDB-supplied trigger	53
A6	Trigger input configured for Kistler NXT32, KiDau, or KiHub (upper drawing) or Kistler DTI Hub (lower drawing)	54
A7	Trigger input configured for generic pigtail cable assemblies	55
A8	Trigger switch wiring example for generic pigtail cable assemblies	55
A9	Armed-out circuit for generic pigtail cable assemblies	56
A10	Example of armed-out indicator light wiring for generic pigtail cable assemblies	56
B1	Cable option for DTS DAS – exit cable #70110 and extension cable #70200	58
B2	Cable option for Kistler NXT32 DAS – exit cable #70115	58
B3	Cable option for generic DAS with exit and breakout cables – exit cable #70120 and breakout cable #70201 with opto-isolated trigger input and armed output	59
B4	Cable option for Kyowa DAS – exit cable #70120 and extension cable #70209	59
B5	Cable option for Kistler KiHub/KiDau DAS – exit cable #70125 and extension cable #70208	60
B6	Cable option for Kistler DTI DAS HUB – exit cable #70125 and extension cable #70218	60

List of Tables

<u>Table No.</u>		<u>Page</u>
1	Summary of LED positions and mounting methods	10
2	Sensor base part numbers and angles	22
3	LED flash order on power-up.....	31
4	Nominal LED positions.....	31
5	Cell-Con battery charger modes.....	42
C1	LED cables #70031 and #70032.....	61
C2	Breakout cable LED connector (6).....	62
C3	Breakout controller connector	62
C4	Exit cable controller connector.....	63
C5	Sensor cable #70051.....	64

HARDWARE USER MANUAL

Second Generation RibEye™ Model #60005 for the WorldSID 50th Male ATD

1.0 WorldSID RibEye Description

The RibEye for the WorldSID anthropomorphic test device (ATD) provides X, Y, and Z position data for 18 light-emitting diodes (LEDs) mounted on the WorldSID ribs. Three LEDs are mounted on each of the six ribs. The RibEye for the WorldSID can be mounted on either side of the dummy to measure left-side or right-side impacts. Model #60005 is the Second Generation WorldSID RibEye. Appendix A provides the RibEye measurement range and other specifications. Up to 3 minutes of data can be collected at a 10-kHz sample rate. Data is stored in non-volatile memory that is retained after power is turned off. If external power is lost, the RibEye will operate on its battery. Communication to the RibEye is via Ethernet.

Two sets of three sensors monitor the LED positions, as shown in Figure 1. The top set of sensors uses red optical filters and monitors the red LEDs mounted on the first three ribs: the shoulder rib, thoracic 1 rib, and thoracic 2 rib. The bottom set of sensors uses blue optical filters and monitors the blue LEDs mounted on the lower three ribs: the thoracic 3 rib, abdominal 1 rib, and abdominal 2 rib.



**Figure 1. RibEye sensors mounted in the dummy
(view from pelvis upward)**

Three RibEye LEDs are mounted on each rib. Figure 2 shows the RibEye LEDs installed in the WorldSID dummy. The center LEDs are mounted on the inner rib clamps. The forward LEDs are closer to the front of the dummy. The rearward LEDs are closer to the dummy's back and are mounted to the rib damping material.

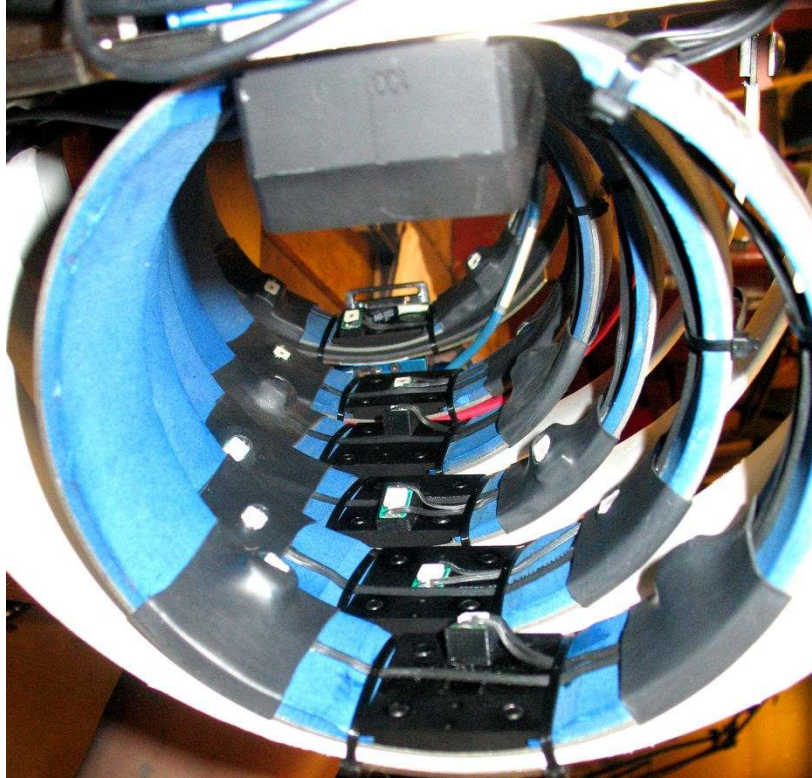

**Figure 2. RibEye LEDs mounted in the dummy
(view from pelvis upward)**

The RibEye controller and battery pack mount on the non-struck side of the dummy. Figures 3–6 show the following views of the controller:

- Figure 3 shows the controller as shipped, with connector covers installed at each end; also shown are the controller mounting plate and the controller mounting feet.
- Figure 4 shows the connectors for the sensors at one end of the controller.
- Figure 5 shows the connectors at the other end of the controller for the LED breakout cable, status cable, battery cable, and dummy exit cable.
- Figure 6 shows the battery pack and the adaptor for mounting the battery pack at the shoulder rib.



Figure 3. RibEye controller with connector end covers in place



Figure 4. Controller sensor connectors



Figure 5. Controller connectors for LED breakout cable, status cable, battery cable, and dummy exit cable



Figure 6. Battery pack and the adaptor for mounting the battery pack at the shoulder rib

2.0 RibEye Installation

This section explains how to mount the RibEye components into the WorldSID 50th Male ATD. The instructions cover the installation of the LEDs, sensors, controller, battery pack, ballast weights, as well as the cable routing. Some components are mounted before the ribs are assembled in the dummy, and others during or after rib assembly. Prior to the RibEye installation the thorax should be disconnected from the Pelvis, and the struck side ribs should be removed.

Order of assembly

1. Mount the LEDs on all of the struck-side ribs, as described in section 2.1.
2. Install a sensor base on the spine, install the rib, attach the sensor front piece to the base, and route the LED cable. These steps follow a prescribed order starting at the bottom rib (abdominal 2) and working upwards. The sensor bases are used to clamp the inner ribs to the spine (sections 2.2.1–2.2.3).
3. Install the controller mounting feet and the battery mount on the non-struck-side (sections 2.3.1).
4. Install the LED breakout cable, also on the non-struck side, and connect the six LED cables to the LED breakout cable (section 2.3.2).
5. Install the controller mounting plate and controller (section 2.3.3).
6. Connect the cables to the controller and install the battery (section 2.3.4).
7. Power up and test the RibEye before final assembly (section 2.3.5).
8. Attach the thorax to the pelvis with the tungsten triangular mass blocks on both sides of the thorax (section 2.4).
9. Install the shoulder pads (section 2.5).
10. Complete dummy assembly (neck, head, and arms) per the ATD Users Manual

2.1 LED installation on the ribs

Table 1 summarizes the LED positions and mounting methods for all 18 LEDs. The following sections describe in detail how to mount the LED assemblies onto the ribs. The forward LEDs are closer to the front of the dummy and the rearward LEDs are closer to the dummy's back, where they are mounted to the rib damping material. A picture of the LEDs mounted to the ribs is shown in Figure 7.

Table 1. Summary of LED positions and mounting methods

Rib number/type		Rearward LEDs	Center LEDs	Forward LEDs
Rib #1 (shoulder)	Position	Bottom edge of rib		
	Mounting	Snap LED assembly to angled block; Tape and heat-shrink in place	LED assembly already glued to LED adaptor plate; Screw LED adaptor plate to clamp plate	Snap LED assembly to angled block; Tape and heat-shrink in place
Rib #2 (thoracic 1)	Position	Center of rib, mounted flat at bottom edge of the rib		
	Mounting	Tape and heat-shrink in place	LED assembly already mounted to clamp plate	Tape and heat-shrink in place
Rib #3 (thoracic 2)	Position	Top edge of rib		
	Mounting	Snap LED assembly to angled block; Tape and heat-shrink in place	LED assembly already glued to angled block; Screw angled block into clamp plate	Snap LED assembly to angled block; Tape and heat-shrink in place
Rib #4 (thoracic 3)	Position	Bottom edge of rib		
	Mounting	Snap LED assembly to angled block; Tape and heat-shrink in place	LED assembly already glued to angled block; Screw angled block into clamp plate	Snap LED assembly to angled block; Tape and heat-shrink in place
Rib #5 (abdominal 1)	Position	Center of rib, mounted flat		
	Mounting	Tape and heat-shrink in place	LED assembly already mounted to clamp plate	Tape and heat-shrink in place
Rib #6 (abdominal 2)	Position	Top edge of rib		
	Mounting	Snap LED assembly to angled block; Tape and heat-shrink in place	LED assembly already glued to angled block; Screw angled block into clamp plate	Snap LED assembly to angled block; Tape and heat-shrink in place

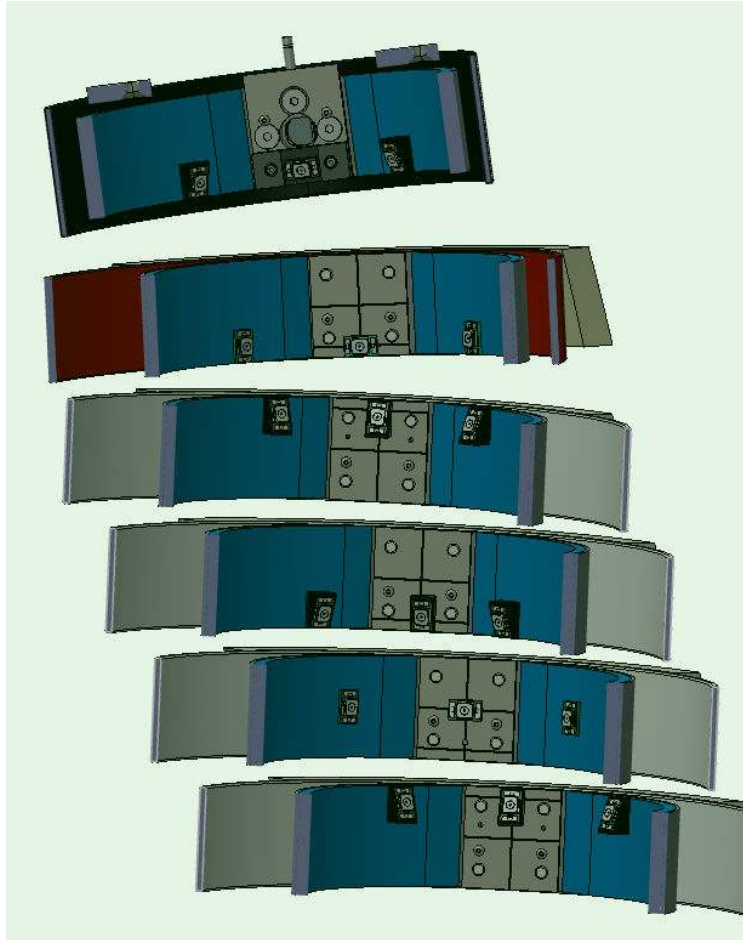

Figure 7. LED positions on each rib

2.1.1 LED assemblies

Figure 8 shows a LED assembly, with its lead cable attached, and an angled mounting block. The LED is soldered onto a metal-clad printed circuit board. Figure 9 shows the LED assembly snapped into the angled mounting block. If the LED does not snap tightly into the angle block, it can be held in place with super-glue (cyanoacrylate) or epoxy. The RibEye is shipped with the LEDs snapped into the blocks. Center LEDs mounted on angle blocks (thoracic 2-3 and abdominal 1-2) are epoxied to the angle blocks.

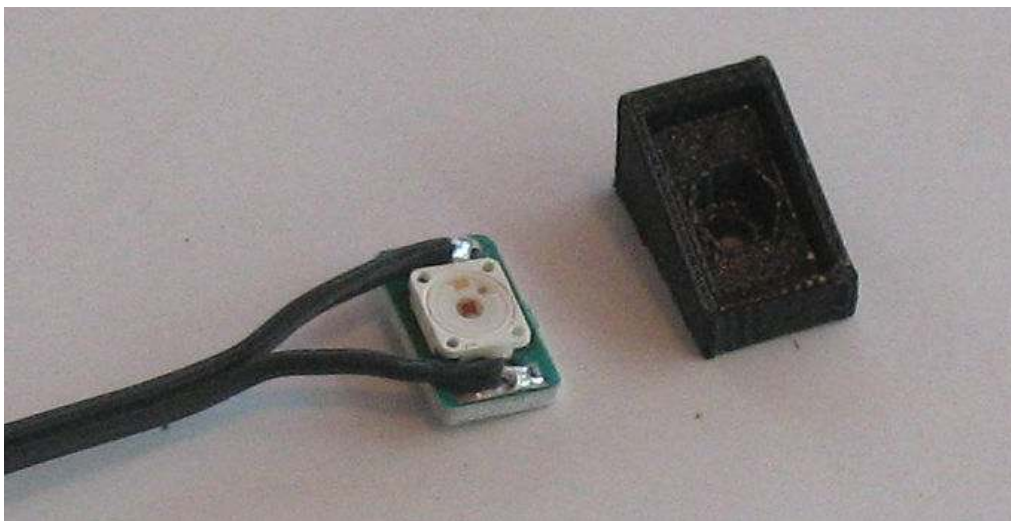

Figure 8. LED and angled mounting block

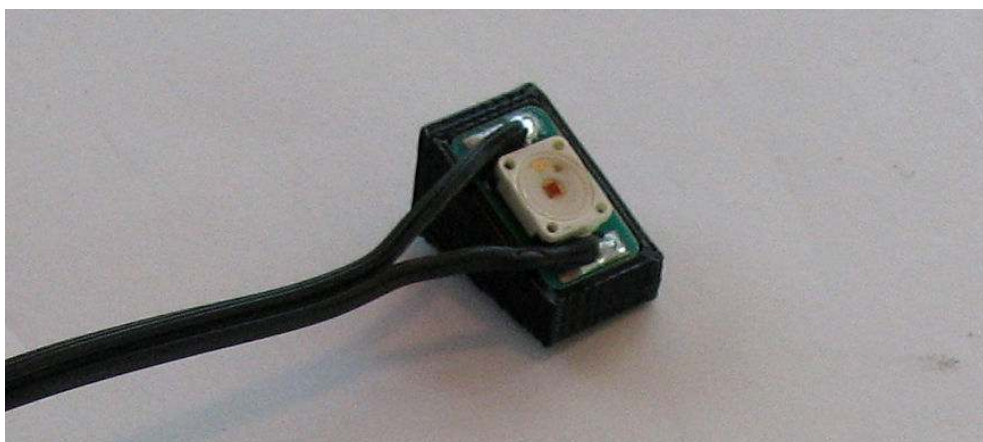

Figure 9. LED snapped into angled mounting block

The angled mounting blocks are used on four of the dummy's six ribs – the shoulder, thoracic 2, thoracic 3, and abdominal 2 ribs. On the shoulder and thoracic 3 ribs, the LEDs are mounted on the bottom edge of the ribs. On the thoracic 2 and abdominal 2 ribs, the LEDs are mounted on the top edge of the ribs.

On the dummy's other two ribs – the thoracic 1 and abdominal 1 – all three LEDs are mounted flat, without a block. The thoracic 1 LEDs are mounted on the bottom edge of the rib, and the abdominal 2 LEDs are mounted in the center of the rib.

The center LED on the shoulder rib is epoxied on to a LED adaptor plate (#10089). The adaptor plate is attached to the shoulder inner rib clamp using two 2-56 x 1/4 button-head cap screws (BHCS).

The shoulder center LED assembly consisting of an inner rib clamp (#10086), LED adaptor plate, and pin for the shoulder pad (#W50-35047) are shown in Figure 10. A second inner rib clamp and pin for the shoulder pad are provided for the non-struck side.

Also shown in Figure 10 are two plastic wire clamps that are bolted to the inner rib clamp plate with 2-56 x 1/4 BHCS. There are two sizes of plastic wire clamps. The smaller wire clamp (0.093-inch diameter) is sized for a single LED cable and is mounted on the left side of the inner rib clamp for the cable that goes to the rear LED. The larger wire clamp (0.125-inch diameter) holds two LED cables and is mounted on the right side of the rib clamp for the two cables that come

from the controller, past the front LED. The description above is for Left-Side impact, directions are reversed for Right-Side impact

The cable clamps are from Micro Plastics Inc.:

- 22CC16A0093-B for the 0.093-inch-diameter clamp
- 22CC16A0125-B for the 0.125- inch-diameter clamp.

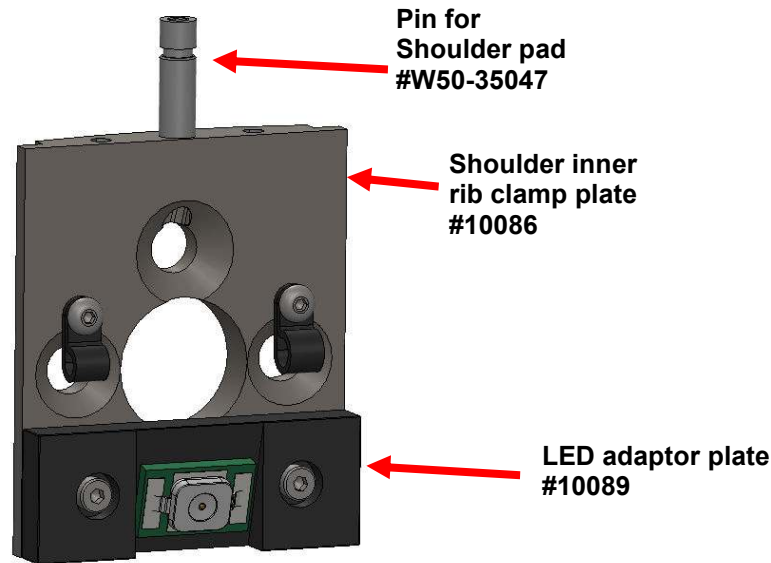

Figure 10. Shoulder center LED adaptor plate, inner rib clamp, pin for shoulder pad, and wire clamps

The center LEDs on the thoracic and abdominal ribs are mounted to inner rib clamp plates #10085. A CAD drawing of an inner rib clamp plate is shown in Figure 11.

- Hole A is for installing the angled blocks, which are screwed to the clamp plates using a 1/4-inch long, 2-56 button-head screw that engages in a captive 2-56 nut inside the angled blocks.
- The two B holes are for mounting the nylon wire clamps using 2-56 x 1/4 BHCS screws.

The scribe lines C are for aligning the LEDs for the thoracic 1 and abdominal LEDs. These LEDs are mounted to the rib clamp plate using 3M VHB tape. The horizontal scribe line at the bottom is for optional mounting of the thoracic 1 LED at the bottom of the rib clamp plate.

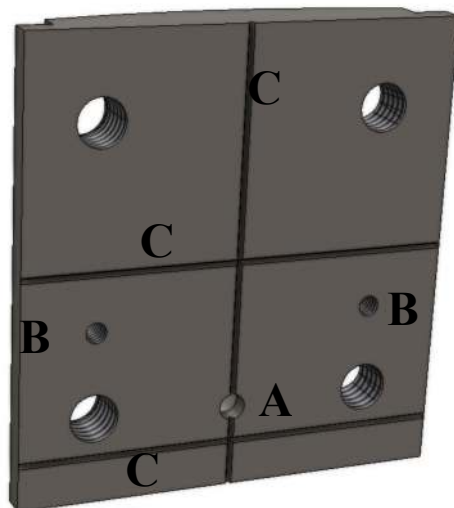

Figure 11. Inner rib clamp plate for thoracic and abdominal ribs

As noted earlier, the forward LEDs are closer to the front of the dummy and the rearward LEDs closer to the dummy's back. These rearward and forward LEDs on all ribs are held in place with high-strength double-sided foam tape and heat-shrink tubing. The foam tape is 3M #4952 (1/2-inch wide, VHB acrylic tape). The heat-shrink tubing is 1-1/4 inches in diameter. The heat-shrink tubing supplied with the RibEye is made by Qualtek, 2:1 shrink ratio, 1-1/4 inches in diameter, part number Q2-Z-1 1/4-01-MS50FT.

Figure 12 shows the inner rib clamp plate with the LED and wire clamps installed for the thoracic 1 rib. Figure 13 shows the inner rib clamp for the abdominal 1 rib. Figure 14 shows the inner rib clamp plate for the thoracic 2, thoracic 3, and abdominal 2 ribs. Thoracic 2 and abdominal 2 have the LED and angle block mounted toward the top of the clamp plate as shown in Figure 14. Thoracic 3 has the LED and angle block mounted to the bottom of the clamp plate—the plate is rotated 180 degrees for the picture shown. For the thoracic 2, thoracic 3, and abdominal 2 angle blocks, there is a captive 2-56 nut installed in the angle block, and a 2-56 x 1/4 BHCS screw hold the angle block to the inner rib clamp

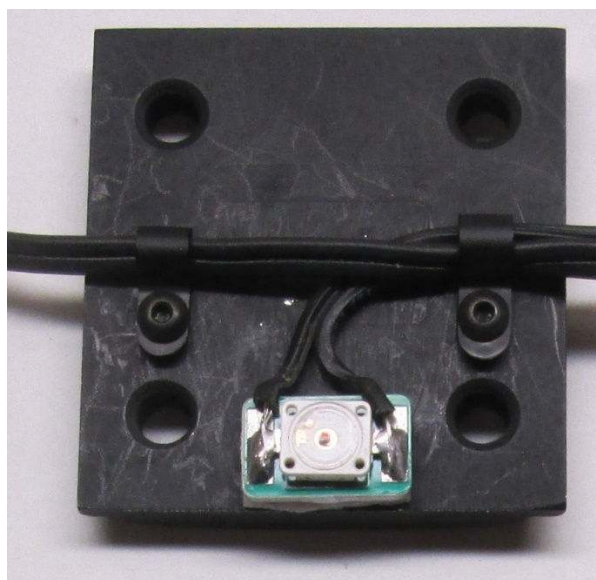

Figure 12. Thoracic 1 inner rib clamp plate with LED and wire clamps installed

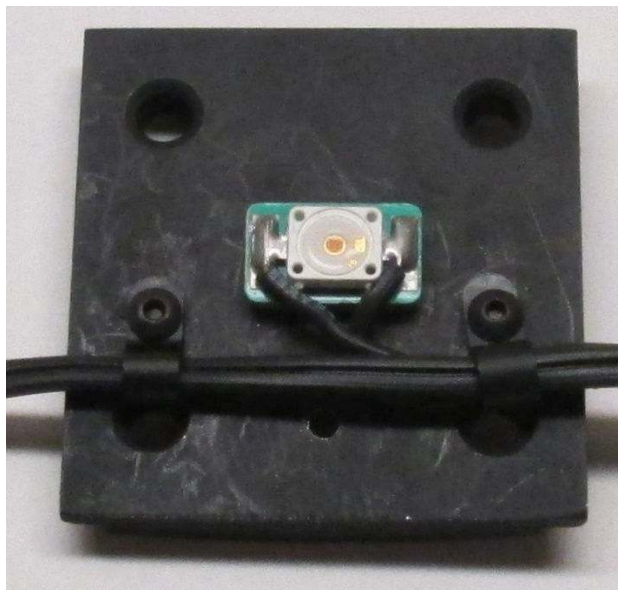

Figure 13. Abdominal 1 inner rib clamp plate with LED and wire clamps installed

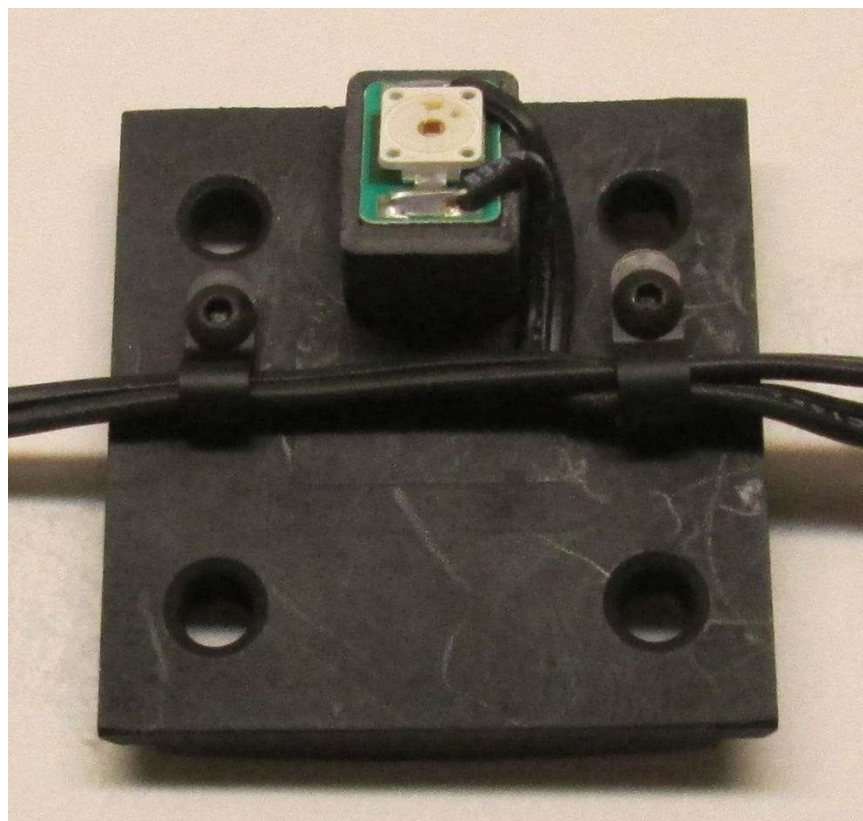

Figure 14. Thoracic 2, thoracic 3, and abdominal 2 inner rib clamp plate with LEDs and wire clamps installed

There is one cable for each rib 3-LED set. Cables #70031 are for the upper three ribs and have red heat-shrink tubing near the connector. Cables #70032 are for the lower 3 ribs and have blue heat-shrink tubing near the connector. Figure 15 shows the #70031 and #70032 cables. The LED closest to the connector is mounted to the front of the rib, the center LED is mounted on the inner rib clamp, and the LED farthest from the connector is mounted on the rear side of the rib.



Figure 15. LED cables #70031 and #70032

The rearward and forward LEDs are typically mounted 35 mm from the center of the rib as shown in Figure 16. The 35-mm dimension is the straight-line distance to the edge of the angled block or 1 mm from the edge of the LED metal-clad printed circuit board.

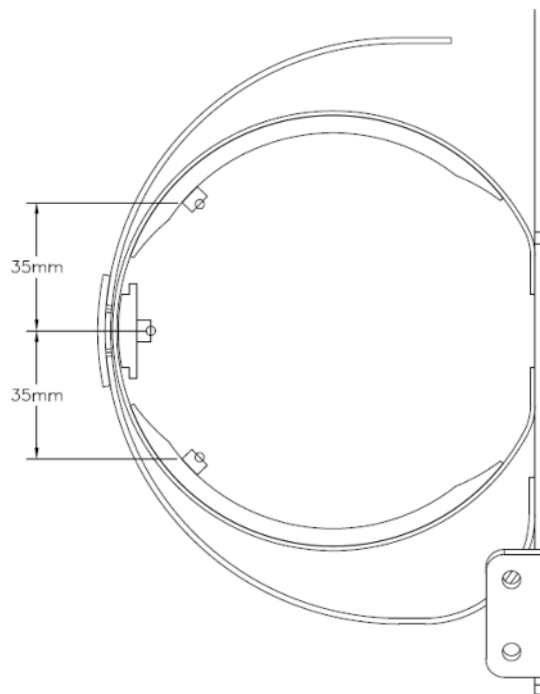

Figure 16. Rearward and forward LED locations

To simplify the mounting of the front and rear LEDs, a LED placement fixture #70300 is available, shown in Figure 17. This fixture holds the rib in place and provides a guide for placing the VHB tape for the front and rear LEDs. Refer to the LED placement fixture instructions for using the fixture. The instructions are available on the RibEye tab of the Boxboro Systems web site (www.boxborosystems.com).



Figure 17. LED placement fixture #70300

The LEDs must be mounted to the ribs before the ribs are installed in the dummy

On each rib, the rearward LEDs should be mounted first, then the center LEDs, and finally the forward LEDs. Before mounting the LEDs, remove grease and mold-release compound by wiping down the mounting area on the ribs and the back of the LEDs and mounting blocks, using isopropyl alcohol. When installing the foam tape, squeeze it onto the rib with at least 15 psi of force. When putting the LED assembly onto the foam tape, press it on with at least 15 psi of force; however, do *not* press on the soft silicone face of the LEDs.

2.1.2 Mounting rearward LEDs on the ribs

The rearward LEDs should be mounted according to the following procedure:

Place a strip of double-stick tape on the rib at the rearward LED mounting location. Add a second piece of tape that will hold the LED cable in position. Place the LED on the first piece of tape and arrange the cable on the second piece of tape so that the cable avoids the spot where the center LED will be mounted (see Figure 18).

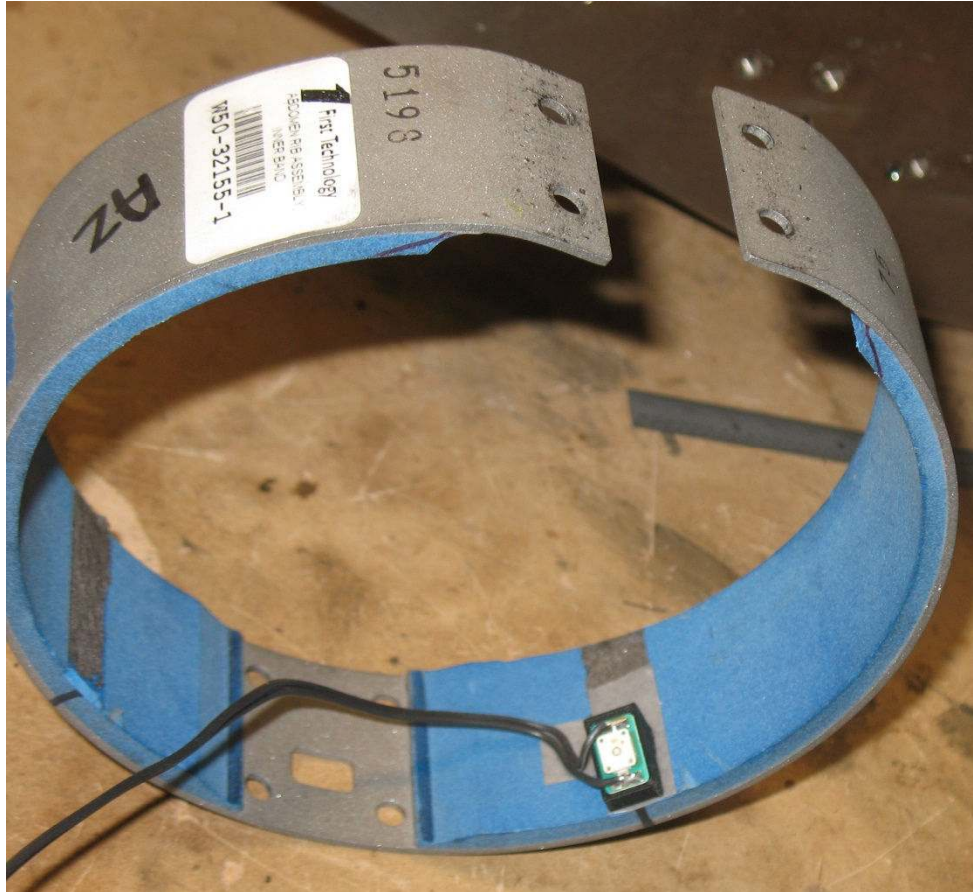

Figure 18. Rearward LED placed on double-stick tape
(with cable arranged to avoid center LED position)

Heat-shrink “sleeves” are provided with the RibEye (tubing that has been pre-cut and hole-punched). To make additional sleeves, cut a piece of heat-shrink tubing 1½ to 2 inches long and punch a hole in the tubing where the center of the LED will be (this can be done using a standard paper hole punch or similar tool). Slide the tubing sleeve over the rib and LED as shown in Figure 19. Center the hole directly over the red or blue square in the center of the LED.

NOTE: Do not use any glue-lined heat-shrink tubing because the glue can bubble out of the LED hole and cover the LED, blocking its light.



Figure 19. Heat-shrink tubing placed over rearward LED

Carefully begin shrinking the tubing using a heat gun while holding the hole over the LED. The heat-shrink tubing will shrink at temperatures of 70 to 100 degrees C.

Danger: Some heat guns are very high temperature. Do not burn yourself.

Start heat-shrinking along the outside of the rib. Then do the inner side of the rib, starting from the edges of the heat-shrink tubing and working toward the center over the LED. When heat is applied to the hole over the LED, the hole will expand, exposing the whole white rectangular body of the LED. You might need to stretch the round hole with your finger so that it fits around the rectangular edge of the LED. Do not touch the soft silicone face of the LED with sharp objects. Figure 20 (right-hand side) shows a rearward LED after the tubing has been shrunk. Make sure that the heat shrink tubing is tight on the rib and can not rotate and cover the LED.

NOTE: It takes a little practice to master the technique of mounting LEDs with heat-shrink tubing. You can always cut off the tubing and try again.



Figure 20. Cable routing for rearward and center LEDs

2.1.3 Mounting center and forward LEDs on the ribs

The next step is to install the center LEDs and route the cables. As noted earlier, the center LEDs are mounted on the inner rib clamp plates, which either have the LED mounted to them or have the LED/angled block screwed into them.

Temporarily install the inner rib clamp with LED assembly using one of the M5 x 12 button-head cap screws. Then place the double-stick tape for the forward LED and route the cables from the center and rearward LEDs as shown in Figure 18 above. Note how the LED cables are routed to avoid crossing in front of any LEDs.

Place the forward LED in position on the double-stick tape and slide a piece of heat-shrink tubing over the LED. The tubing should also cover all three LED cables. Heat-shrink the tubing over the forward LED in the same way described above for the rearward LED. When heat-shrinking is complete, the tubing will hold the LED and the cables in place.

In addition, put strips of heat-shrink tubing holding the cables from the forward LED position to where the rib is attached.

NOTE: It is important to secure all the cables so that they do not block the light from the LEDs to the sensors during a test.

2.1.4 Alternative method for mounting LEDs on the ribs

Some customers have mounted the forward and rearward LEDs on the ribs using only the 3M VHB tape, while using strips of heat-shrink tubing for cable management as shown in Figure 21. The idea behind the alternative method is that, by not putting the heat-shrink material over the LEDs, you eliminate any risk that the material could rotate during a test and cover the LED; also, less heat is required to shrink the tubing tightly around the LED.



Figure 21. Alternative mounting of rearward and forward LEDs

2.2 Installation of ribs and sensor assemblies on the spine

NOTE: For customers who will be connecting the RibEye exit cable to Kistler NXT32 DAS systems mounted between the spine plates, you should attach the RibEye exit cable to the NXT32 now. The RibEye exit cable for the NXT32 system (cable #70115) connects to the last NXT32 in the chain. The last NXT32 is mounted at the top of the dummy's thorax between the spine plates.

To access the connector on the NXT32 interface module, remove the neck adaptor from the top of the thorax by removing the six M6 x 10 flat-head cap screws (three on each side) that hold the neck bracket to the spine plates. You can then plug in the Harwin connector end of the RibEye exit cable to the mating receptacle on the last NXT32 interface module. Replace the neck bracket with the six M6 x 10 screws.

2.2.1 Installation of sensor bases on spine with mounting screws

The RibEye's sensor assemblies take the place of the existing rib-to-spine clamps. Each sensor assembly contains a sensor front piece and a sensor base for mounting it to the spine. It is the sensor bases that act as the rib clamps.

The sensor bases are installed to the spine's existing rib-mounting holes using four special M5 x 10 flat-head cap screws that have precision-machined shoulders. Figure 22 shows the M5 x 10 shoulder screws. The shoulder screws ensure that the sensor bases are properly aligned to the spine.

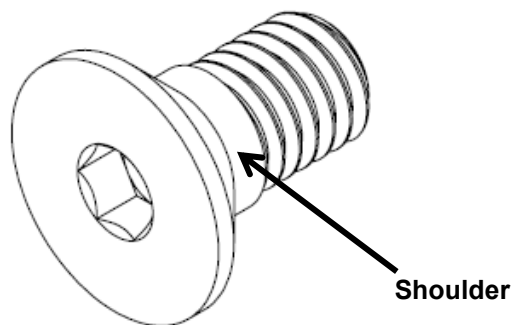

Figure 22. M5 x 10 flat-head cap screw with precision-machined shoulder

The sensor bases have different angles depending on their mounting positions (Table 2).

Table 2. Sensor base part numbers and angles

Rib	Sensor Base Part Number	Base Angle, degrees
Shoulder	10071-11	11
Thoracic 1	10071-0	0 (flat)
Thoracic 2	10071-23	23
Thoracic 3	10071-20	20
Abdominal 1	10071-0	0 (flat)
Abdominal 2	10071-20	20

The sensor bases have a label on the inside with the RibEye serial number (S/N), rib number, the rib name, and the screw installation order, as shown in Figure 23. To install the sensor bases, use four shoulder screws. Install the first screw in the upper-left hole (position 1) and tighten the screw loosely – “finger tight”, so the base can still rotate about the screw. Next, install the second screw in the lower-right hole (position 2) and tighten the screw finger tight. Then put in screws in positions 3 (upper-right) and 4 (lower-left). Finally, tighten the screws in the order 1-2-3-4.



Figure 23. Sensor base with label

Figure 24 shows the sensor bases mounted to the spine.

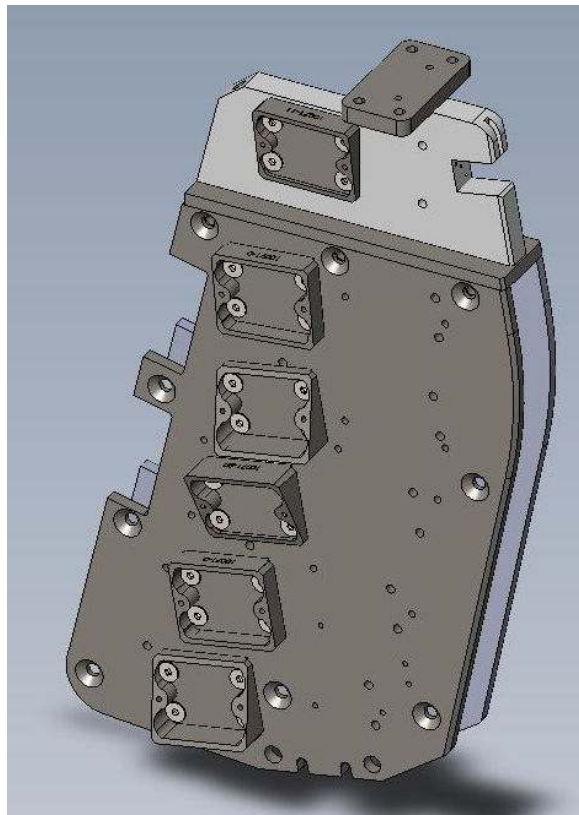

**Figure 24. RibEye sensor bases mounted to spine
(ribs not shown)**

2.2.2 Mounting sensor front pieces to sensor bases

The sensor front piece containing the electronics and optics (Figure 25) is attached to the sensor base by two M3 x 16 flat-head cap screws. Although the sensor front pieces look identical, each piece is marked with the RibEye serial number (S/N) and the number of the rib that it must be mounted on. The sensor front piece must be installed on that rib. However, the sensor front pieces are not mounted to their bases until the ribs are in place inside the dummy (see section 2.2.3 below).

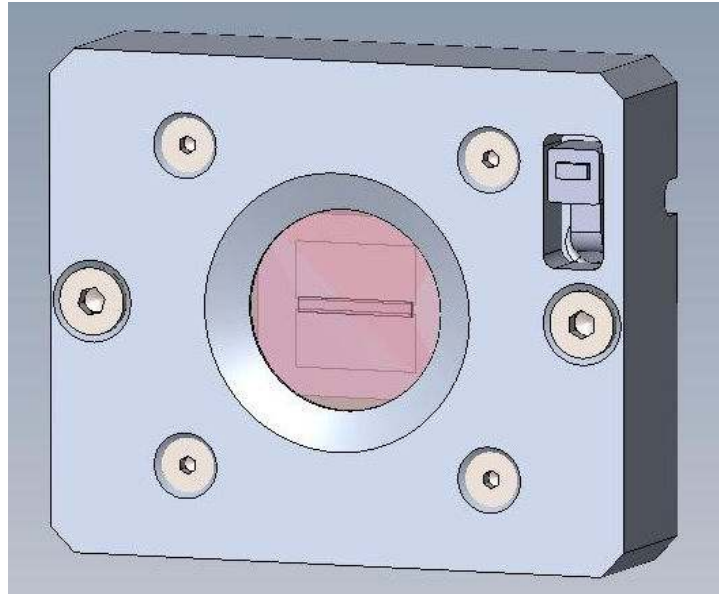

Figure 25. RibEye sensor front piece

WARNING: *Never remove the sensor printed circuit board or loosen the circuit-board mounting nuts. Doing so will ruin the calibration of the RibEye.*

Figure 26 shows the back side of the sensor front piece with the label showing the rib it must be installed on. Note that the sensor front pieces must be installed so that the cable is oriented to the rear of the dummy for left-side impact. For right side impact the cable is oriented to the front of the dummy. The sensor has two alignment pins that fit into mating holes on the sensor bases.

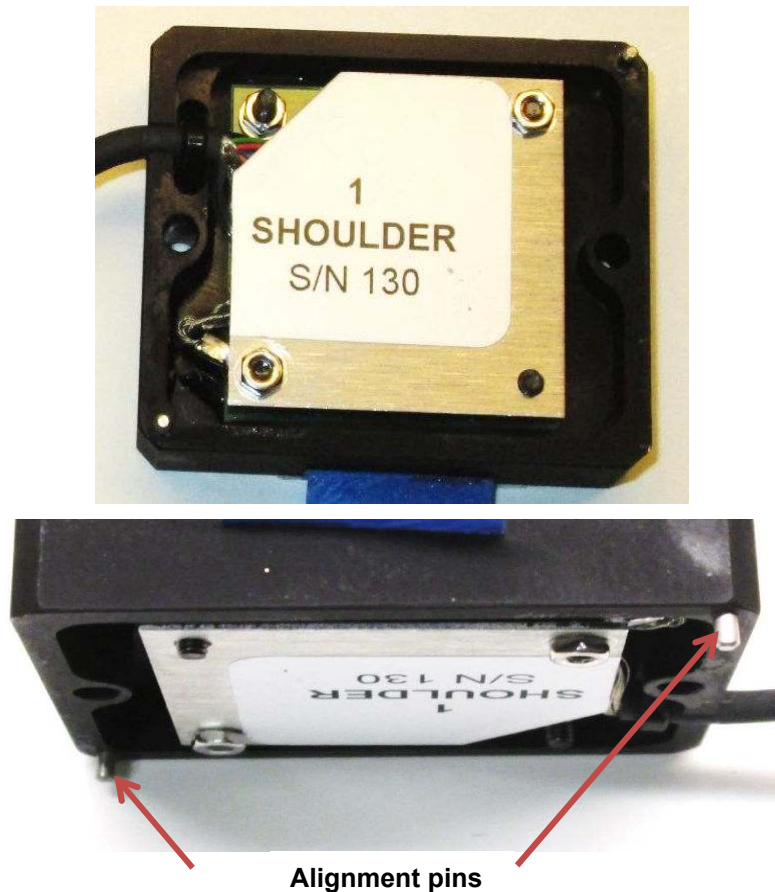

Figure 26. RibEye sensor label on back (top) and alignment pins (bottom)

Figure 27 shows the spine with the entire sensor assemblies installed (bases and front pieces). However, the sensor front pieces are not mounted to their bases until the ribs are in place inside the dummy (section 2.2.3 below).

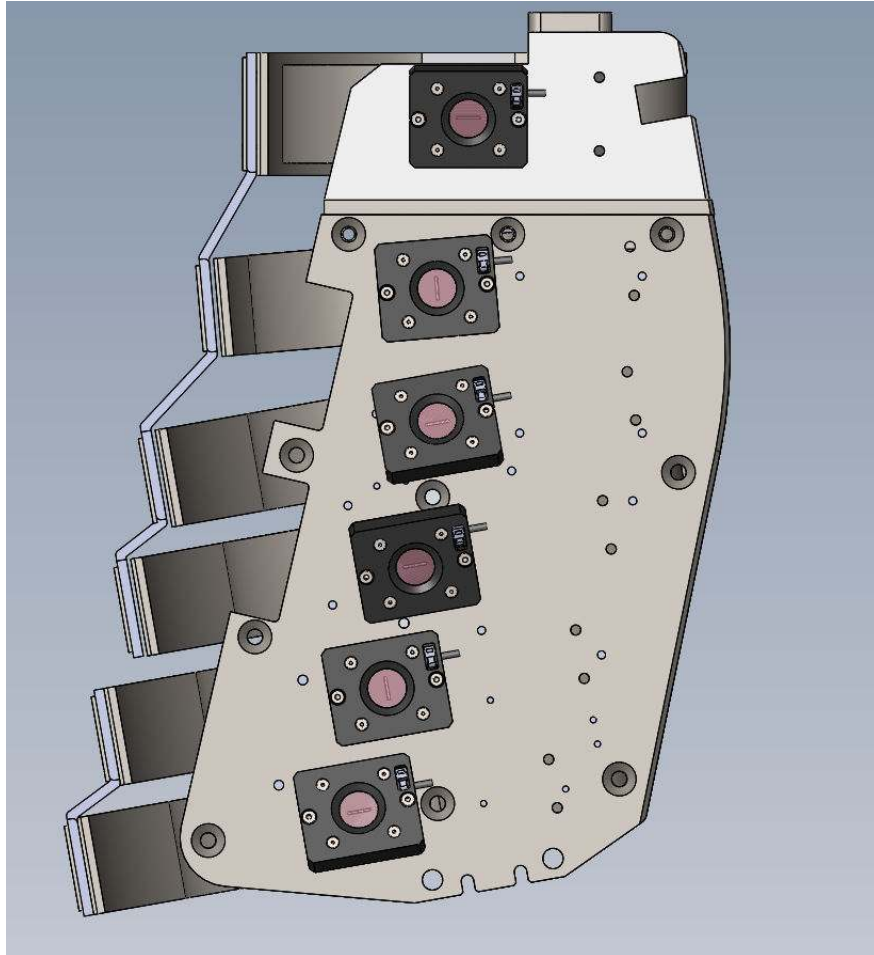

Figure 27. RibEye sensor assemblies mounted to spine
(ribs not shown)

2.2.3 Installation of ribs on spine and routing LED cables

Install the ribs on the spine, starting with the bottom rib (abdominal 2) and working up, in the following order:

- Install outer rib.
- Install inner rib to spine using sensor base and shoulder screws.
- Connect the outer rib to the inner rib using the clamp plates and bolts supplied with the dummy.
- Attach sensor front piece to base.
- Route cable up to shoulder. Attach cable to next sensor cable using a nylon zip tie at the point where the cable exits the sensor.
- Route LED cables as follows:
 - Abdominal 2 through thoracic 2: LED cable exits TOP of rib
 - Thoracic 1 and shoulder rib: LED cable exits BOTTOM of rib
 - Cables go over the front of the dummy to its non-struck side.

Figure 28 shows the bottom 3 ribs installed. Sensors are installed on the abdominal 1 and 2 ribs, and the thoracic 3 rib is installed with the sensor base ready for mounting the sensor front piece on thoracic three. Note that the painters tape that is shipped covering the sensor glass is left on during installation to prevent getting smudges on the lenses.

The sensor cables are routed upwards to the next sensor and zip-tied to the sensor cable close to the sensor. Assure that the cables are tight and can not move up (away from the spine) and block or reflect light into the sensors.

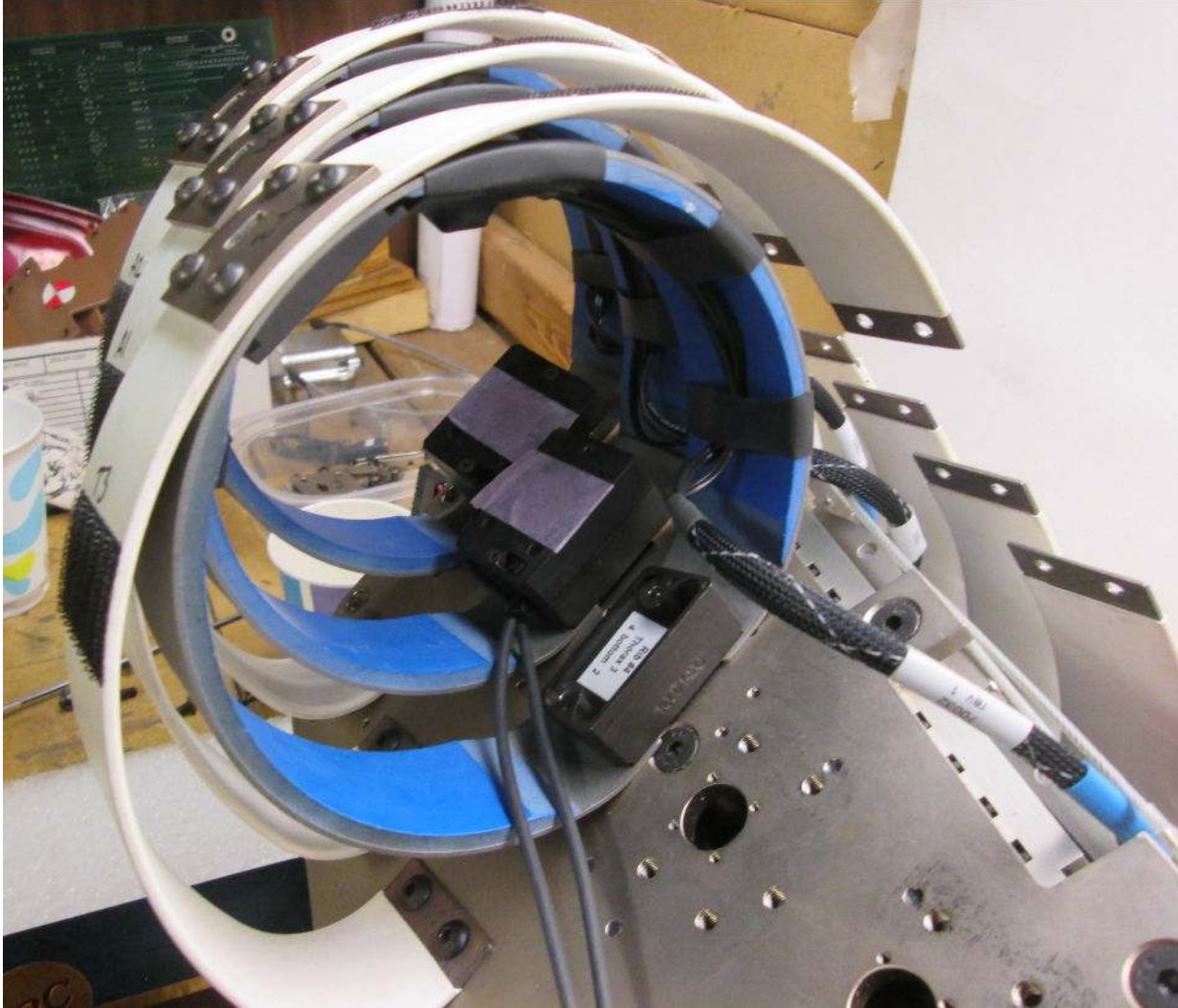

Figure 28. Lower three ribs – abdominal 2, abdominal 1, and thoracic 3 – and RibEye sensor assemblies mounted to spine

The upper three ribs installed are shown in Figure 29. The dummy shown has a temperature sensor on the thoracic 1 rib, and its cable is routed to join the sensor cable bundle. The sensor cable bundle is routed to the non-struck side under the neck bracket as shown.

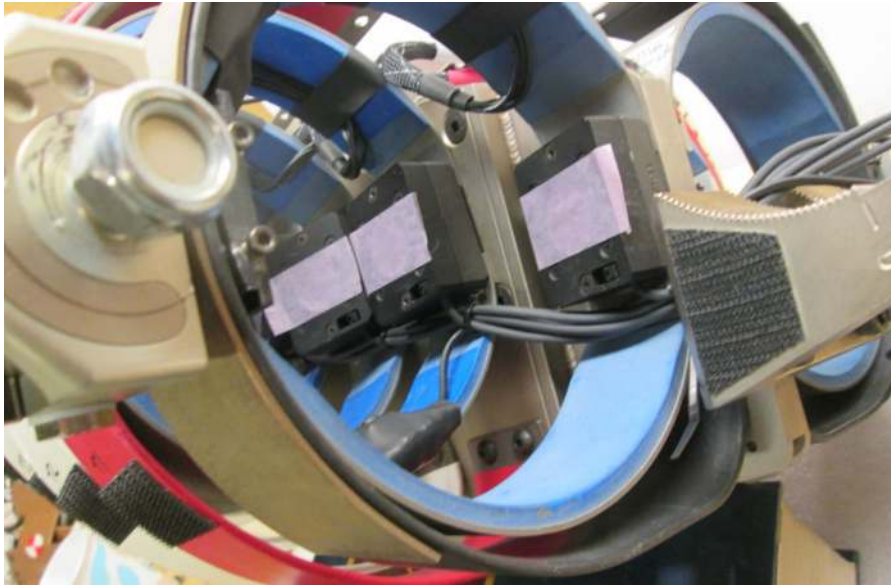

Figure 29. Upper three ribs – thoracic 2, thoracic 1, and shoulder – and RibEye sensor assemblies mounted to spine

For right-side impact configuration, the sensor cables exit the sensors toward the front of the dummy, and are routed similarly to the left-side impact described earlier. Above the shoulder, the sensor cables go over the top of the shoulder rib to the non-struck side (Figure 30).

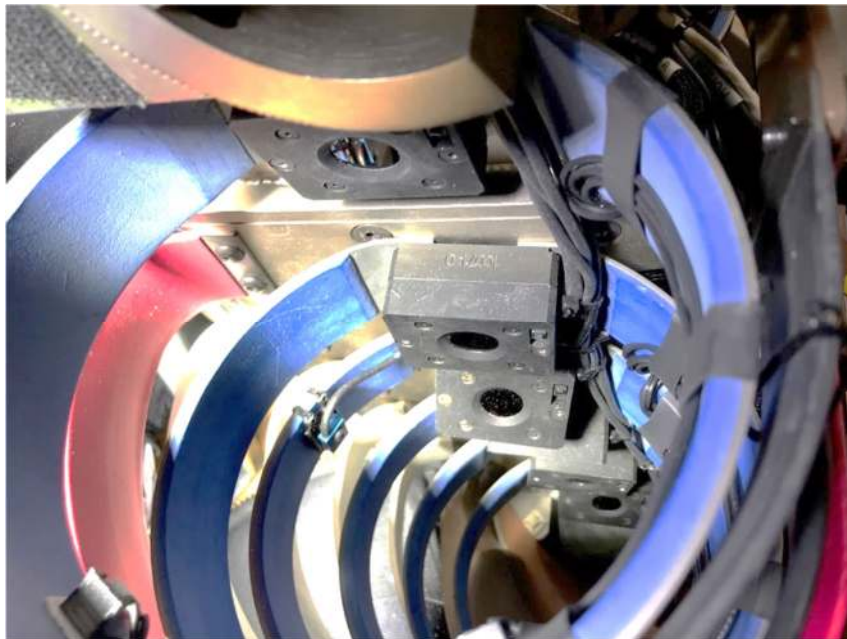

Figure 30. Right-side impact sensor cable routing

Figure 31 shows the LED cables exiting the ribs over the top of ribs abdominal 2 and 1 and thoracic 3 and 2. The LED cables exit bottom of the thoracic 1 rib and the shoulder rib. Note that the outer ribs on the struck side are removed for clarity. Figure 32 also shows the LED cables routed over the sensor connector blocks, with all outer ribs installed

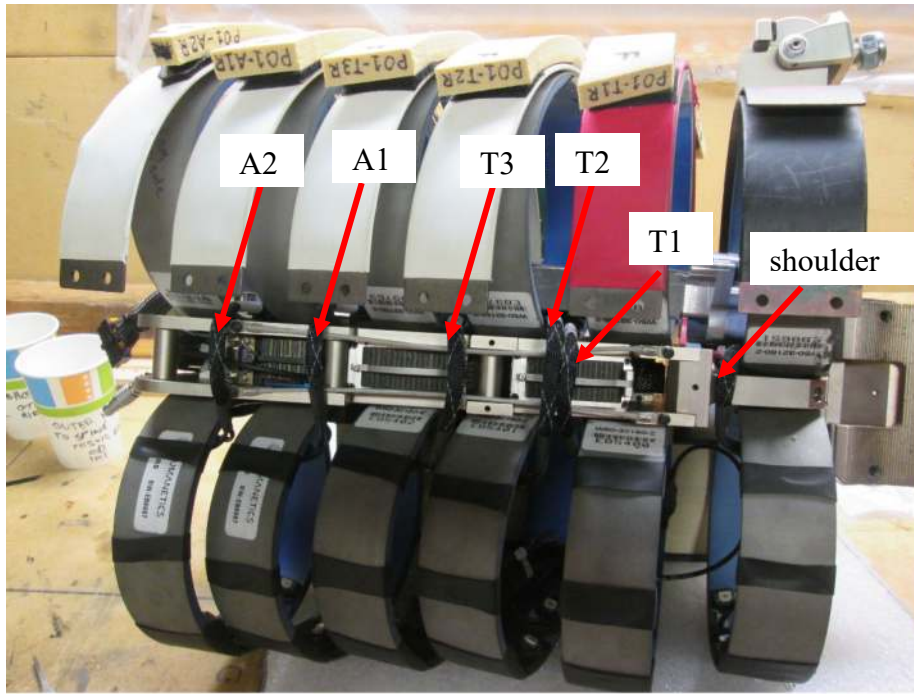

Figure 31. LED cables exiting the top of ribs abdominal 2 through thoracic 2 and the bottom of thoracic 1 and abdominal 1 (outer ribs removed for clarity)



Figure 32. LED routed to non-struck side

2.3 Installing components and quick-testing RibEye operation

This section describes mounting and connecting the LED breakout cable, the controller, the battery base, and the shoulder inner rib clamp on the non-struck side, then connecting the sensor cables to the controller, installing the battery, and verifying RibEye operation.

2.3.1 Mount the controller feet, battery base, and shoulder inner rib clamp

The controller and controller mounting plate attaches to two controller feet (#10081) that take the place of the rib clamps on the non-struck side of the thoracic 1 rib and the abdominal 2 rib (Figures 33 and 34). The feet are installed by removing the four rib clamp bolts, removing the rib clamp plates, and then installing the feet using four M5 x 10 flat-head cap screws, which are provided with the RibEye.

The RibEye battery mounts to a battery base (#60413) that replaces the shoulder rib clamps on the non-struck side as shown in Figure 35. The battery base is installed by removing the four rib clamp bolts, removing the rib clamp plates, and then installing the battery base using four M5 x 10 flat-head cap screws, which are provided with the RibEye.

Replace the shoulder inner rib clamp (W50-32171) with the #10086 inner rib clamp and shoulder foam pin (W50-35047) (see Figure 36).

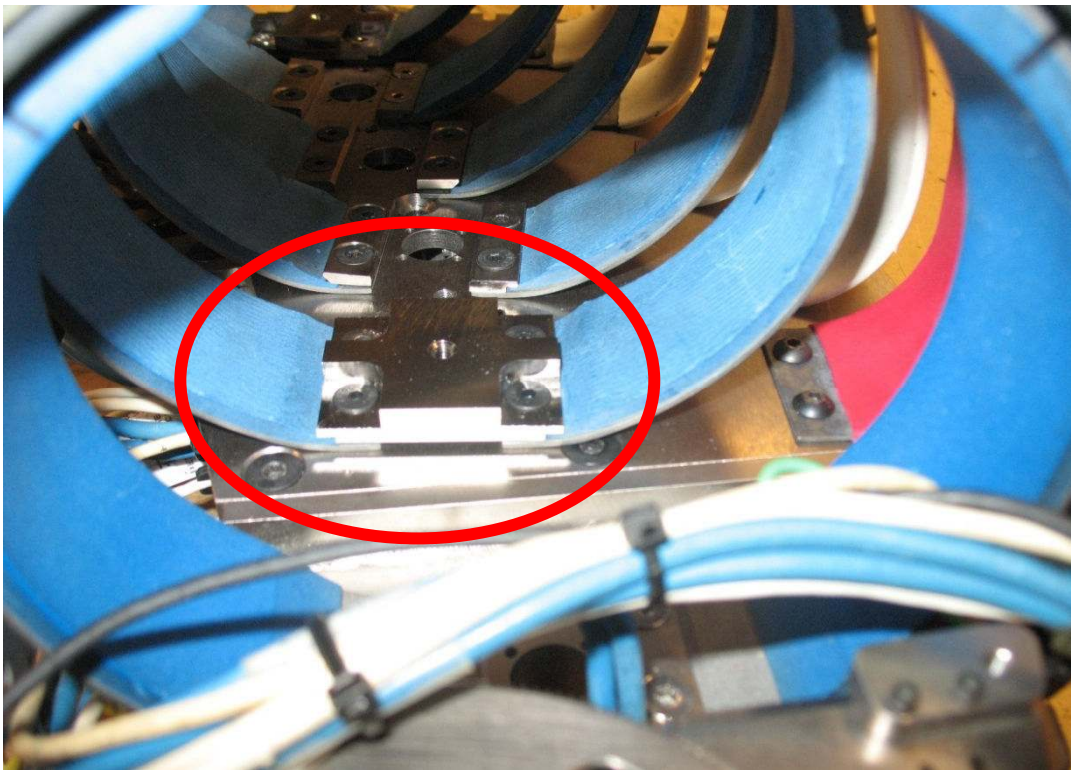

Figure 33. Controller foot installed on thoracic 1 rib

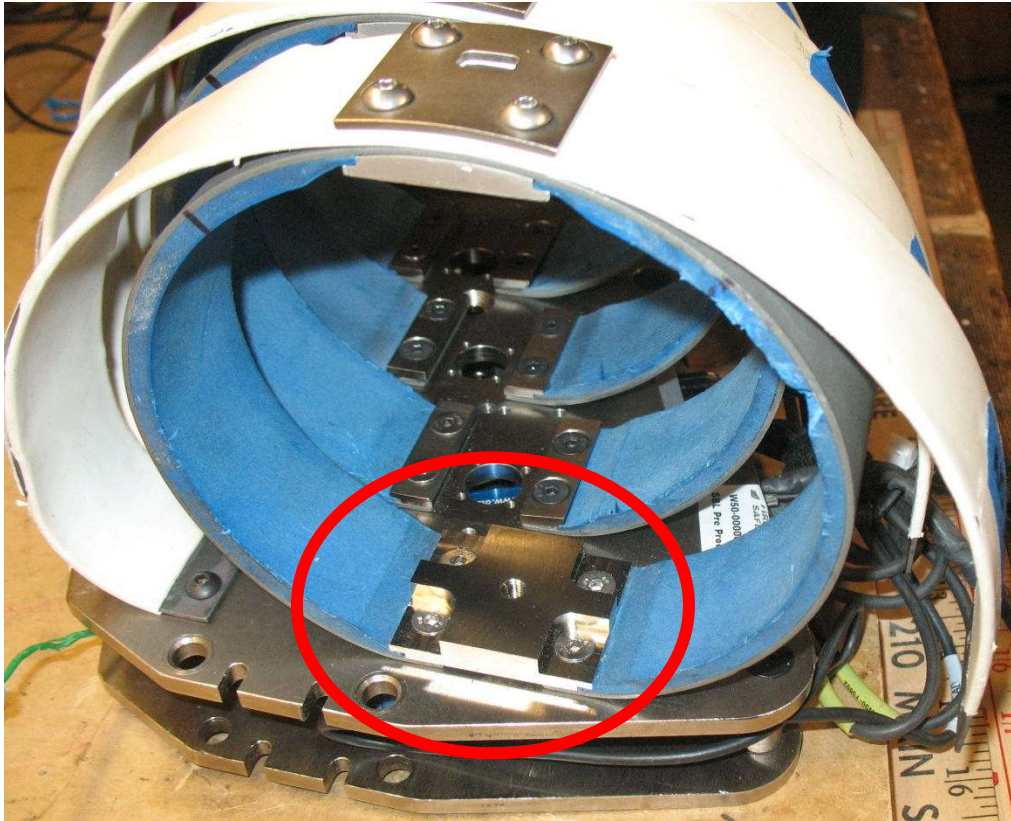

Figure 34. Controller foot installed on abdominal 2 rib

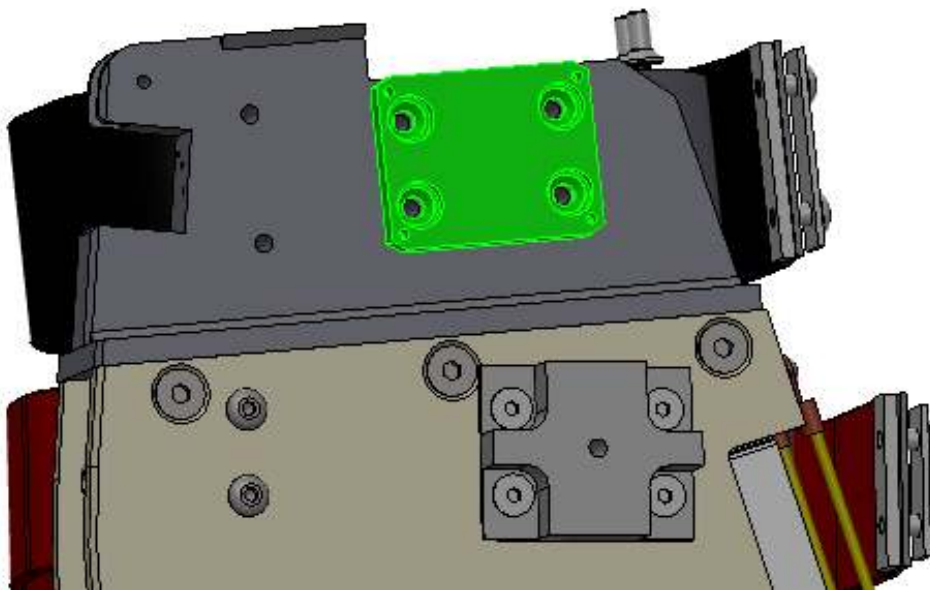

Figure 35. Battery base (highlighted in green) installed on shoulder rib (ribs hidden)

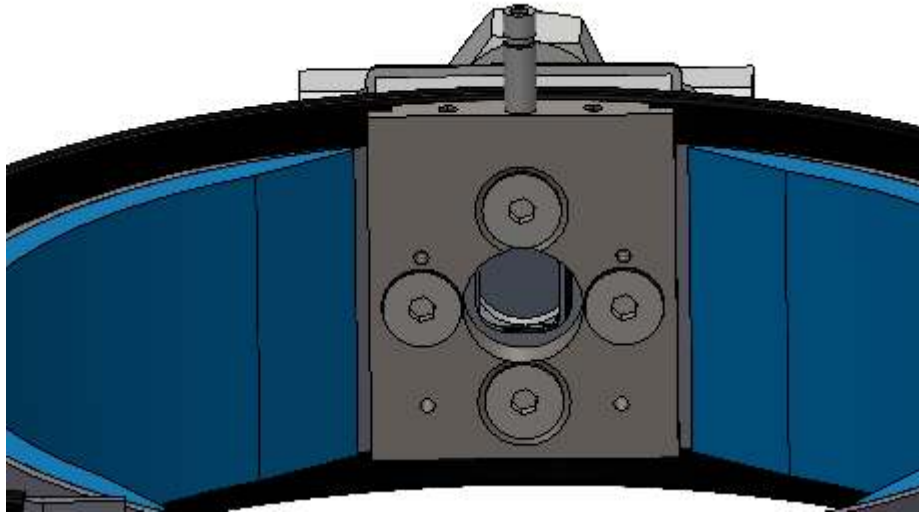

Figure 36. Shoulder inner rib clamp and shoulder foam pin installed

2.3.2 Install the LED breakout cable

The LED cables plug into a #70030 breakout cable shown in Figure 37. The LED cables from each rib plug into the connectors numbered 1 through 6, where connector 1 is for the shoulder rib and connector 6 is for the abdomen 2 rib.



Figure 37. LED cables plugged into #70030 breakout cable

The breakout cable mounts to the inner ribs 30-35 mm from the spine ends of the ribs toward the rear of the dummy as shown in Figure 38. The shoulder LED connector (#1) lies just above, toward the shoulder of the thoracic 1 controller foot. The remaining connectors lie between the thoracic 1 and abdominal 2 controller feet as shown in Figures 38 and 39. Hold down the breakout cable to the inner ribs using nylon zip-ties.

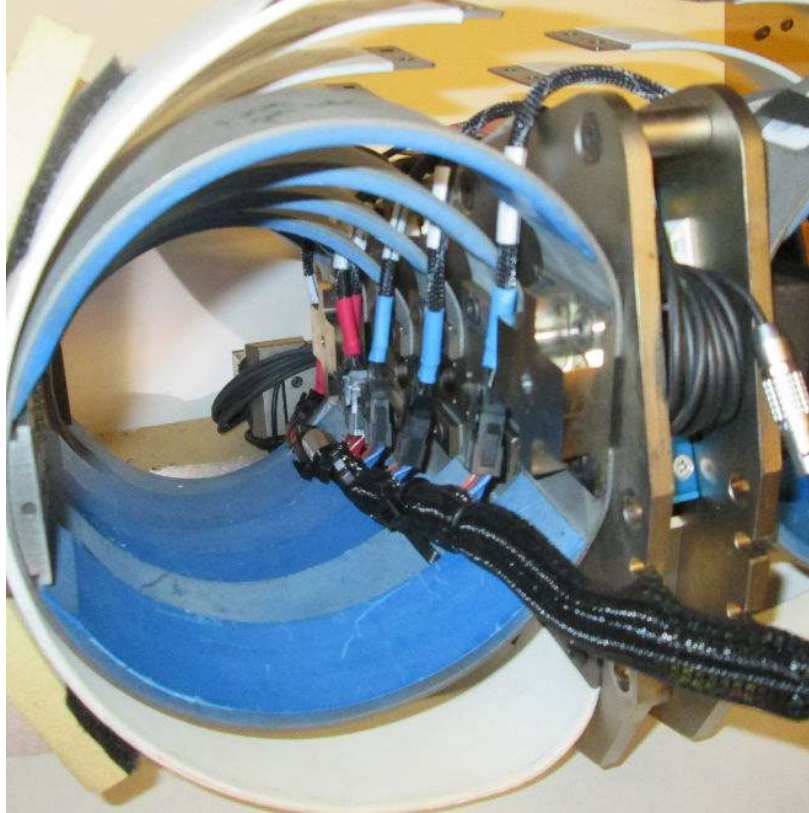

Figure 38. LED breakout cable – view from pelvis with LED cables plugged in



Figure 39. LED breakout cable – view from head with LED cables plugged in

2.3.3 Install the controller mounting plate and controller

The controller mounting plate (#60408) attaches to the controller feet using two M5 x 10 FHCS (flat head cap screws) as shown in Figure 40.

The controller mounts to the controller mounting plate using four M5 x 10 FHCS as shown in Figure 41 (circled in red). Prior to mounting the controller, remove the two controller end covers by removing the four M3 x 6 SHCS (socket head cap screws).

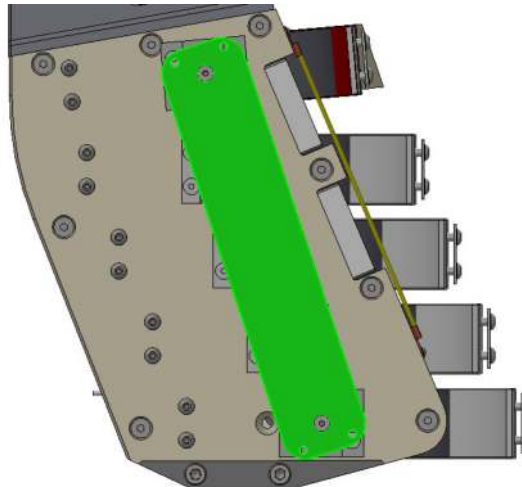

Figure 40. Controller mounting plate (in green) bolted to the controller feet

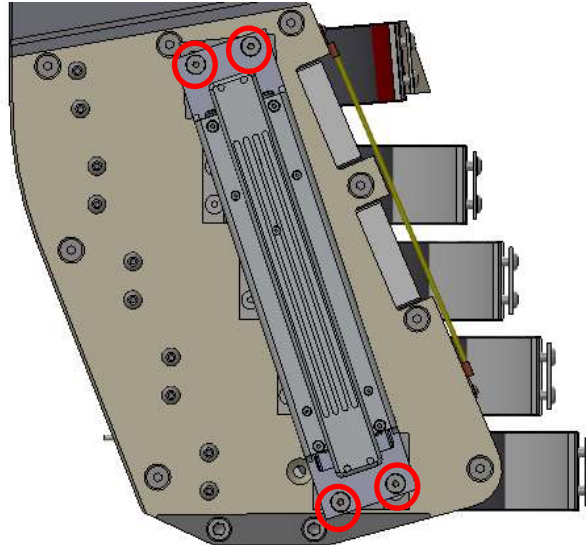

Figure 41. Controller attached to controller mounting plate (ribs hidden)

2.3.4 Connect cables to controller and install battery

The sensor cables plug into the sensor jacks on the top of the controller (refer back to Figure 4). The cables and the jacks are marked 1 through 6, where 1 is the shoulder sensor and 6 is the abdominal 2 sensor. After the sensor cables are plugged in, install the connector cover on the sensor end of the controller with two M3 x 6 SHCS.

Next install the battery to the battery mount using four M3 x 8 SHCS as shown in Figure 42. Orient the battery so the cables exit toward the controller. The battery cables should run down the rearward side of the controller toward the pelvis. After the battery is installed, tie any extra sensor cable to the shoulder rib.

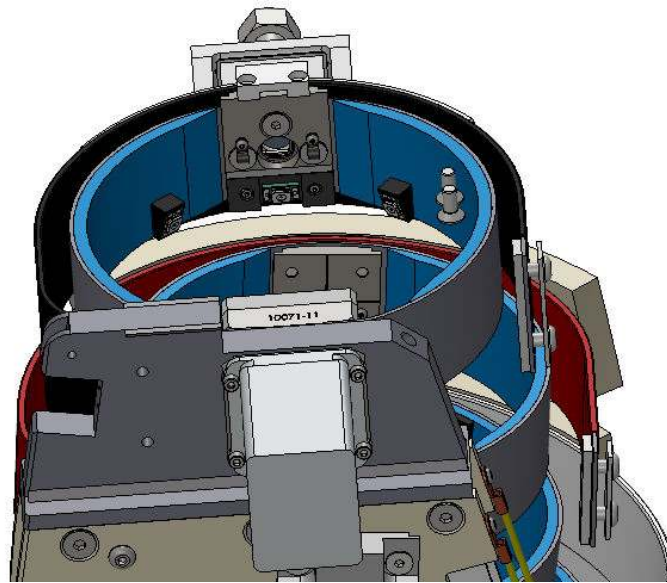

Figure 42. Battery box attached to battery mount at shoulder (shoulder rib not shown)

At the bottom end of the controller the connector panel has jacks for:

- LED breakout cable – marked “LEDs”
- Status LED – marked “STATUS”
- Battery power/communication cable – marked “BATT”
- Dummy exit cable – marked “EXIT”

The bottom connector panel is shown in Figure 43 (and above in Figure 5). For all of the jacks, the locking tab is toward the center of the connector panel.

- First plug in the LED breakout cable into the LEDs jack
- Second plug in the battery power/communication cable into the BATT jack
- Then plug in the LED status cable into the STATUS jack
- Finally plug in the dummy exit cable to the EXIT jack.

After the cables are plugged in, re-install the connector cover using the two M3 x 6 SHCS, then secure the cables with zip ties.

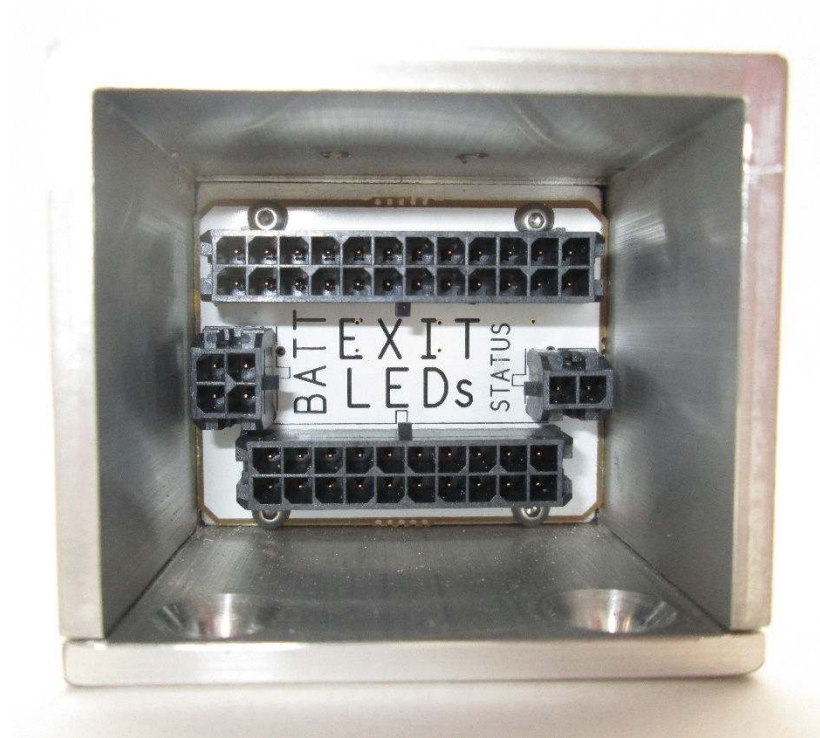

Figure 43. Connector panel at bottom of controller

The status LED cable is routed to the outside of the dummy. It has a LED on it that flashes at different rates so you can see that the RibEye is working and what state it is in (see Section 3.2).

The battery charger cable should be routed to wherever it is convenient for you to plug in the charger.

All of the external connections to the WorldSID RibEye controller – power, trigger, and Ethernet - are in the exit cable. Boxboro Systems provides several cable options to connect the WorldSID RibEye controller to the customer’s equipment to get power, trigger, and Ethernet connections. Refer to Appendix B for a list of the cable options and drawings for connecting to various DAS systems.

2.3.5 Verify operation via quick test prior to completing ATD assembly

At this point the RibEye can be tested to verify proper operation prior to finishing the dummy assembly.

Plug the exit cable assembly into your DAS (see Appendix B for cable assemblies) and power up the RibEye. When the RibEye powers up you should see the status LED flash slowly. The LEDs on the ribs will turn on in the following order, for about 1 second per set (Table 3).

Table 3. LED flash order on power-up

Time	Rib and Position	
	Upper Rib Set (Red)	Lower Rib Set (Blue)
1	Shoulder rear	Thoracic 3 rear
2	Shoulder middle	Thoracic 3 middle
3	Shoulder front	Thoracic 3 front
4	Thoracic 1 rear	Abdominal 1 rear
5	Thoracic 1 middle	Abdominal 1 middle
6	Thoracic 1 front	Abdominal 1 front
7	Thoracic 2 rear	Abdominal 2 rear
8	Thoracic 2 middle	Abdominal 2 middle
9	Thoracic 2 front	Abdominal 2 front

If you haven't already done so, remove tape covering the sensor lenses. Then power up and connect to the RibEye, using the RibEye 7.0 software (refer to the RibEye Software Manual 7.0). Click on the "Show Current XYZ's" button to display the current positions of all of the LEDs. There should be no error codes (see Section 3.5). The reported positions should be within a few millimeters of the positions shown in Table 4.

Table 4. Nominal LED positions

LED #	Rib #	Position	X	Y	Z
1	1	REAR	-55	-84	-55
2	1	MIDDLE	-20	-96	-56
3	1	FRONT	14	-83	-59
4	2	REAR	-37	-99	-1
5	2	MIDDLE	1	-108	0
6	2	FRONT	37	-98	-1
7	3	REAR	-28	-96	42
8	3	MIDDLE	6	-106	43
9	3	FRONT	40	-97	47
10	4	REAR	-49	-93	-36
11	4	MIDDLE	-19	-101	-34
12	4	FRONT	12	-92	-35
13	5	REAR	-34	-96	-2
14	5	MIDDLE	0	-105	-1
15	5	FRONT	33	-96	-2
16	6	REAR	-13	-93	34
17	6	MIDDLE	19	-104	32
18	6	FRONT	49	-96	34

After the quick test, you should power down the RibEye and complete the ATD assembly.

2.4 Install mass blocks at bottom of thorax

There are two tungsten mass blocks (part #60416) that are installed when connecting the thorax to the pelvis. The mass blocks are shown in Figure 44 highlighted in green. Each mass block is held in by two M8 x 1.25 x 30 SHCS that go through the mass block and the spine plate and into the threaded holes in the lumbar mounting wedge.



Figure 44. Mass blocks #60416 installed at bottom of thorax

2.5 Install shoulder pads

Top and bottom views of the shoulder pad assembly are shown in Figure 45. The shoulder pad assembly consists of a left pad and right pad and two brackets. The hat shaped bracket is to the front of the dummy. The short rectangular bracket is to the rear of the dummy on the struck side. Left side impact positions are shown. For right-side impact, switch the rectangular bracket to the right side pad.

The shoulder rib clamps have posts sticking up vertically from the rib clamps (shown in Figure 10 and Figure 36). The shoulder pads have a molded-in receivers for the posts at the outboard edge. Drop the shoulder pad over the post so it engages with the receiver molded into the pad.

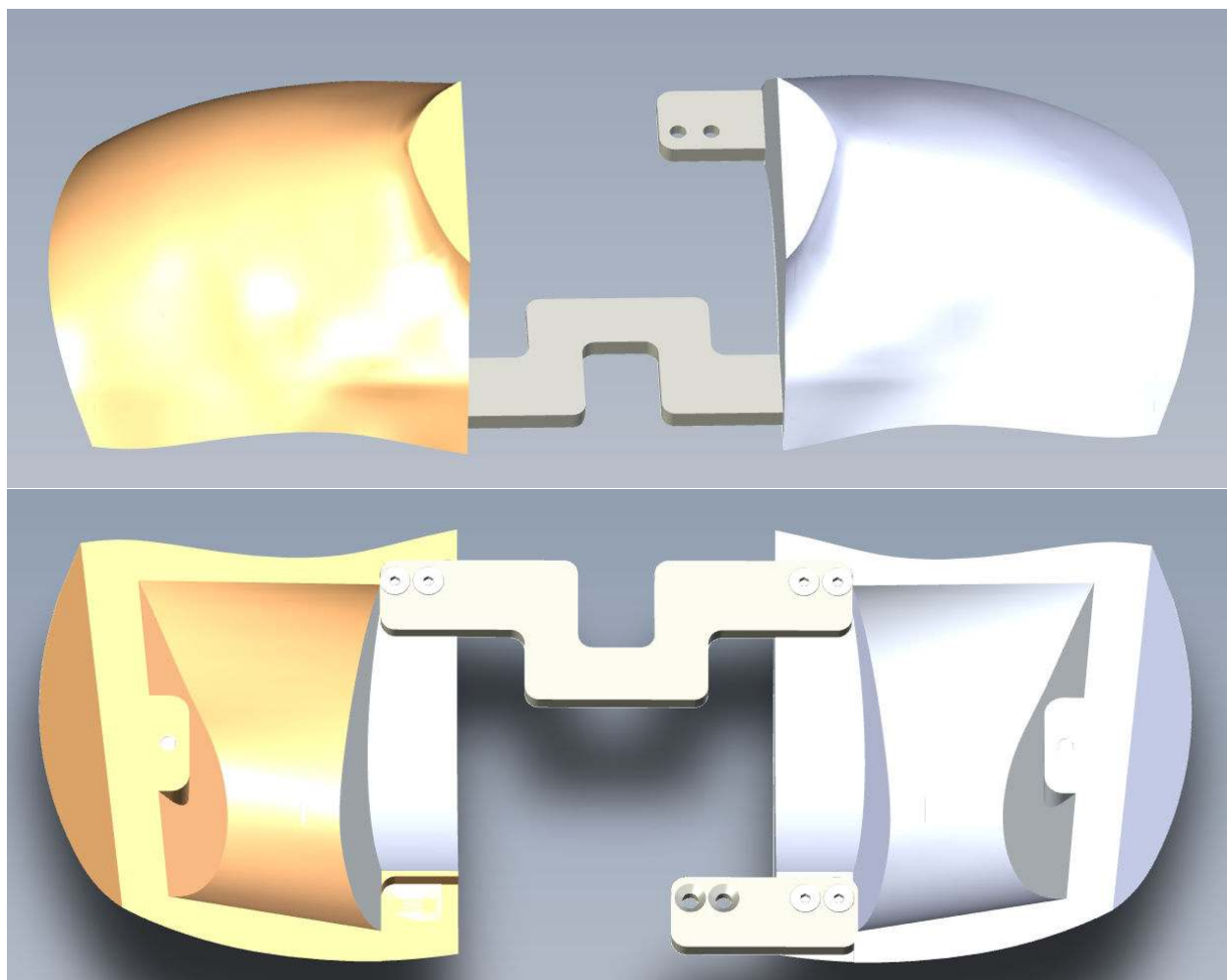

Figure 45. Top and bottom views of the shoulder pad assembly

3.0 RibEye Operation

This section describes the operation, the coordinate system, and the connections used in the RibEye. The RibEye for the WorldSID can be mounted on either side of the dummy to measure left-side or right-side impact. If the RibEye will be used for right-side impacts, it must be calibrated for the right side. When ordering the RibEye, specify left, right, or both side impacts.

Please refer to the RibEye Software User Manual 7.0 for software details and instructions on how to change the RibEye network's IP address. The manual is included on the USB thumb drive shipped with the RibEye and can also be downloaded from our website, www.boxborosystems.com.

3.1 Data coordinate system

As noted earlier, two sets of three sensors each monitor the LED positions. The top set of sensors monitors the red LEDs mounted on the first three ribs (shoulder, thoracic 1, and thoracic 2). The bottom set of sensors monitors the blue LEDs mounted on the lower three ribs (thoracic 3, abdominal 1, and abdominal 2).

Position data from each sensor set is reported with respect to a coordinate system that has its origin in the center (middle) sensor of each set (Figure 46). For both upper and lower rib sets, the origin of the coordinate system is 21 mm from the face of the spine plate in the Y direction.

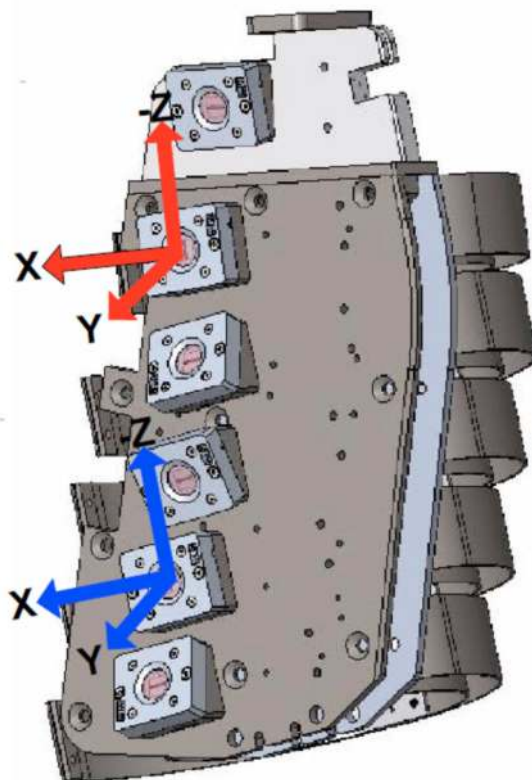

Figure 46. RibEye coordinate system

For the top three ribs –

- The center of the coordinate system is the center of the inside face of the lens in the sensor mounted on the thoracic 1 rib. (Note that the inside face is 2 mm from the outside face.) The X-axis is parallel to the rib, the Y-axis is perpendicular to the spine plate, and the Z-axis is perpendicular to the rib.
- The shoulder rib center in the X direction is 19.86 mm to the rear of the thoracic 1 rib.
- The thoracic 2 rib center in the X direction is 4.72 mm to the front of the thoracic 1 rib.

For the lower three ribs –

- The center of the coordinate system is the center of the inside face of the lens in the sensor mounted on the abdominal 1 rib. The X, Y, and Z axes are the same as for the upper sensor set (X parallel to the rib, Y perpendicular to the spine plate, and Z perpendicular to the rib).
- The thoracic 3 rib center in the X direction is 20 mm to the rear of the abdominal 1 rib
- The abdominal 2 rib center in the X direction is 20 mm to the front of the abdominal 1 rib.

For R&D testing, the LEDs can be placed anywhere within the RibEye's measurement range (see Appendix A-1). For example, a user could place nine LEDs on a single rib to show the shape of the rib.

3.2 Status indicator

The status light flashes at varying rates to indicate that the RibEye is operating and what it is doing:

- 0.5 Hz = idle with data in memory
- 1.0 Hz = idle with memory erased
- 2.0 Hz = acquiring data
- 10 Hz = erasing flash memory or downloading data

3.3 Ethernet link and activity lights

There are two lights on the side of the controller; the Ethernet link light, and the Ethernet activity light.

3.4 Batteries and charger

The backup battery for the RibEye is mounted on the shoulder rib. A picture of the battery pack assembly was shown previously in Figure 6. Figure 47 shows the battery pack and the battery shoulder rib adaptor installed in the dummy on the non-struck side.

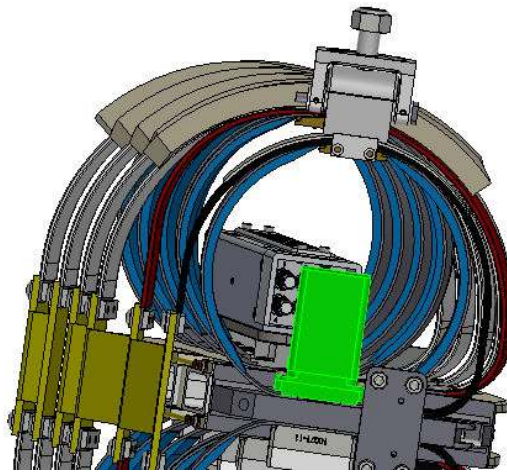

Figure 47. Battery pack and adaptor (shown in green)

The RibEye battery pack consists of 12 AAA NiMH batteries. There are two cables coming out of the battery pack:

1. Power/communications cable with a 4 pole Microfit connector that plugs into the bottom connector panel on the controller.
2. A 2.5 mm coaxial charger jack for plugging in the Cell-Con battery charger.

The RibEye batteries are turned on only when the RibEye is armed or storing collected data to flash memory. They will provide a minimum of 20 minutes of run-time. The batteries are only charged when the charger is plugged in. The RibEye software will display the battery charge level and voltage. Refer to the RibEye Software Manual 7.0 for more information on the battery status display. The RibEye battery pack has a self-resetting polymer fuse on its power input. If this fuse ever opens, it can take up to 4 hours to self-reset.

The charger for the RibEye battery pack is a Cell-Con Model 452115-01071-3311. A LED on the charger indicates its current mode, as shown in Table 5. Figure 48 shows the charger and the battery cable charger receptacle. Please refer to the Cell-Con manual, which is supplied with the charger, for information on safety, operation, maintenance, etc. Note that the charger should be plugged into the RibEye battery *before* it is plugged into a power outlet.

Table 5. Cell-Con battery charger modes

LED Color	Mode
Orange	Battery not connected
Orange	Battery initialization and analysis (7 seconds)
Red	Fast charge
Green with intermittent orange flash	Top-off charge
Green	Trickle charge
Alternating Red-Green	Error



Figure 48. RibEye battery pack Cell-Con charger and battery cable charger receptacle

3.5 Error codes

If the RibEye cannot calculate a LED position, the software will insert error codes in the data. If an error code occurs, data from all three axes, X, Y, and Z, will be forced to the same error code.

Usually error codes occur when the light from a LED is blocked and cannot reach one of the sensors. Typically, this results when a loose cable gets between the LED and the sensor. Also, if the center rib on either set of three ribs compresses significantly more than the upper or lower ribs of the set, it can block the light from the upper or lower rib LEDs to one of the sensors. Too much ambient light can also cause the RibEye to generate error codes.

If an error code occurs, you must discount the data for a few milliseconds before and after the drop-out in the plots. Before and after the light is completely blocked, the obstacle partially blocks light, which confuses the sensor and causes bad data to be reported. That's why a few milliseconds of data must be discounted before and after the blockage and drop-out.

NOTE: The error codes can get masked by filtering the data. Therefore, we strongly recommend reviewing and saving a copy of the unfiltered data so that the error codes are preserved.

The error codes for each sensor set are as follows:

1. The top sensor is blocked or sees too much ambient light
2. The bottom sensor is blocked or sees too much ambient light
3. Both top and bottom sensors are blocked or see too much ambient light
4. The middle sensor is blocked or sees too much ambient light
5. The middle and top sensors are blocked or see too much ambient light
6. The middle and bottom sensors are blocked or see too much ambient light
7. All three sensors are blocked or see too much ambient light
8. A divide-by-zero condition occurred in the data processing
9. Out of range error.

The out-of-range error, code 9, occurs when the data from the sensor goes beyond the end of a calibration curve, indicating that the LED moved significantly out of the RibEye's guaranteed range.

To verify that a LED has moved out of range, create X-Y or Z-Y plots of the RibEye's absolute data and overlay the range limits on the plot. An example is shown below in Figure 49. RibEye software will generate X-Y and Y-Z plots with the RibEye range overlaid.

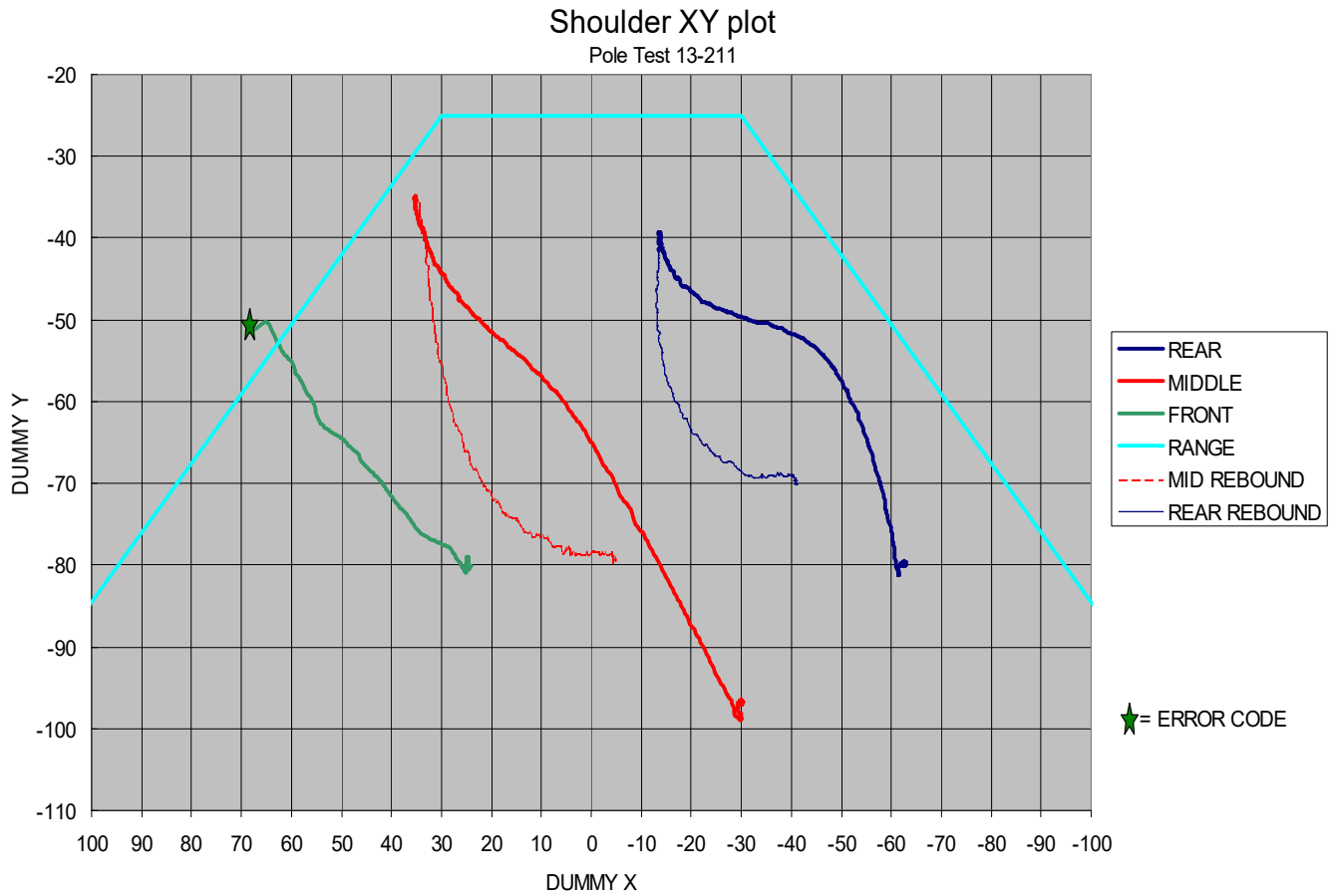

Figure 49. Plot overlay verifying whether LED moved out of range

4.0 RibEye Maintenance

The only maintenance required for the RibEye is to keep the sensor lenses clean.

A dirty camera lens will create a fuzzy photo, and smudged eyeglasses will distort vision. The same holds true for RibEye: If the lenses are not clean, the data will be less accurate.

Make sure that the lenses are clean before each and every test.

If the lenses need to be cleaned, follow this procedure:

1. Blow dust off the lenses with clean, dry air.
2. If there is grease or dirt on the lenses, clean them with eyeglass or camera-lens cleaning solution and lens cleaning paper or a lens cleaning cloth. You can also use isopropyl alcohol.
3. Make sure there is no residue from the cleaning solution remaining on the lens.

WARNING: *DO NOT USE cotton-tipped swabs like Q-Tips. They leave fibers on the lens.*

Note: If you can't get enough light into the thorax to see the lenses well, you can arm the RibEye to turn on the LEDs.

DANGER: *Do not look directly at the LEDs, as they are very bright.*

Also clean the inside of the dummy to remove all loose debris such as dirt, pieces of foam, and zip-tie ends. Any objects, even very small, that are flying around inside the dummy during a test can interfere with the light from the LEDs to the sensors, causing spikes in the data.

WARNING: *Never remove the sensor printed circuit board or loosen the circuit-board mounting nuts. Doing so will ruin the calibration of the RibEye.*

4.1 Dummy maintenance for RibEye

The inside of the thorax must be kept clean. Dirt and other particles can fly through the field of view between the LEDs and the sensors during a test, causing data spikes and anomalies. We recommend vacuuming or blowing out the thorax to remove any loose particles.

Appendix A. RibEye specifications

A-1. Measurement accuracy and range

The RibEye meets the requirements of SAE J211/1 (July 2007) as a combined sensor and data acquisition system. It also meets the ISO 6487-2000 specifications.

Figure A1 shows the RibEye measurement range in the X-Y plane for all six ribs. The plot also shows the LED positions.

Figure A2 shows the RibEye measurement range in the Y-Z plane for the upper set of three ribs (shoulder, thoracic 1, and thoracic 2). The plot also shows the LED positions for all of the upper three rib LEDs.

Figure A3 shows the RibEye measurement range in the Y-Z plane for the lower set of three ribs (thoracic 2, abdominal 1, and abdominal 2). The plot also shows the LED positions for each of the lower three rib LEDs.

The maximum error for the Y and Z data is less than 1 mm, and the maximum X error is less than 1.5 mm.

WorldSID 50th XY range - All Ribs front, rear, and center LED positions

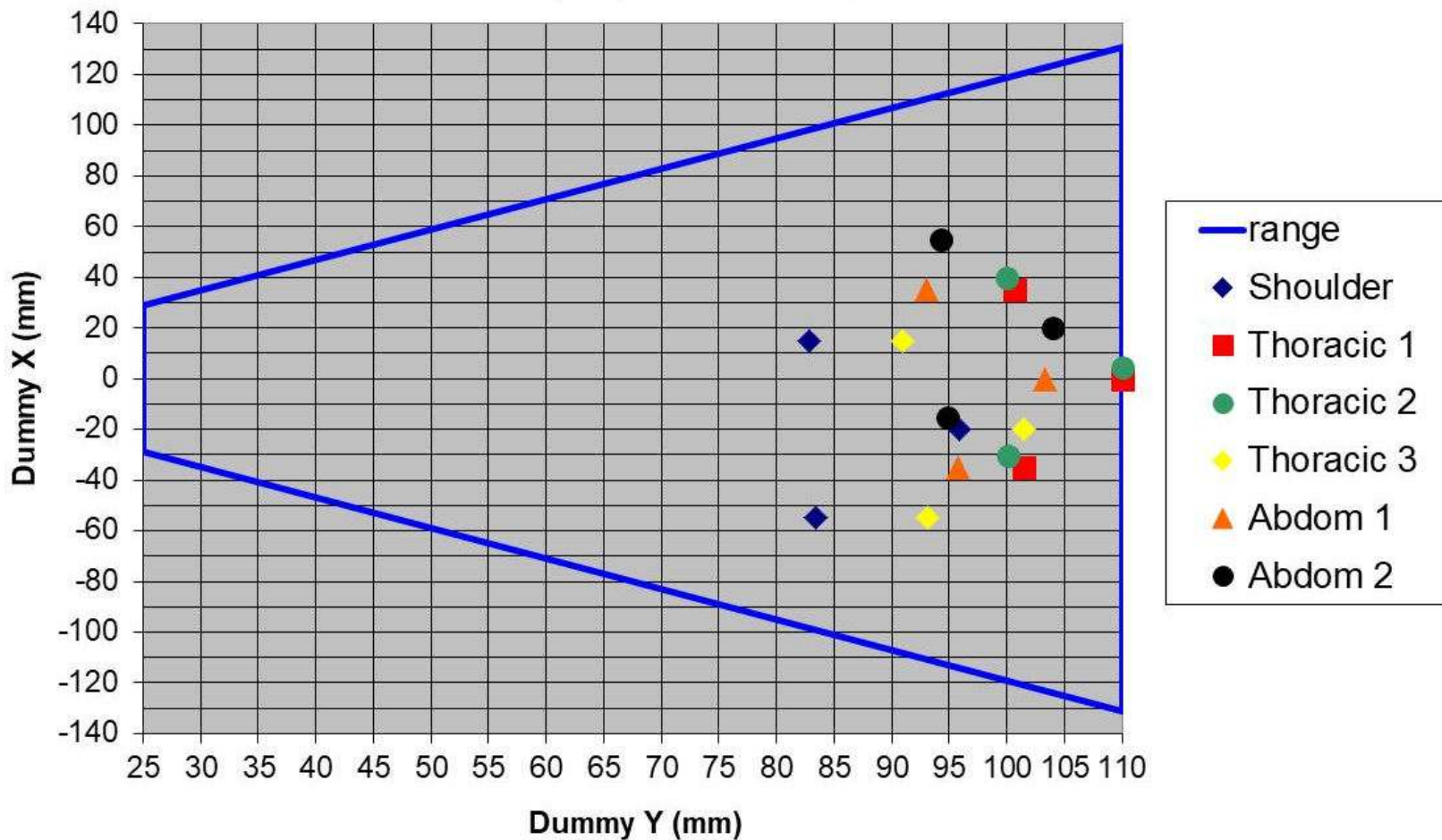

Figure A1. RibEye measurement range in X-Y plane – all ribs

WorldSID 50th RibEye YZ Range - Upper Ribs front, rear, and center LED positions

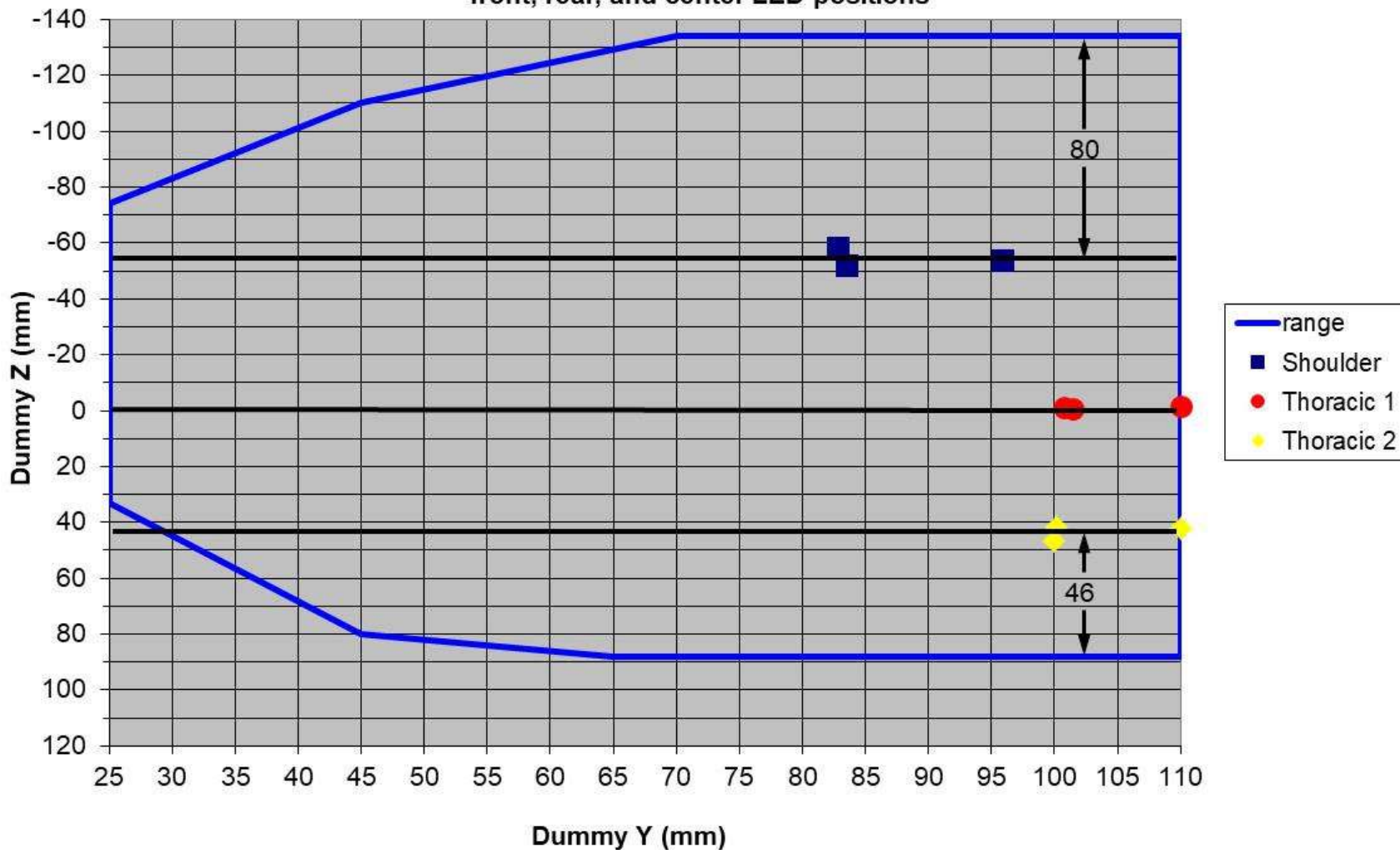

Figure A2. RibEye measurement range in Y-Z plane – upper three ribs

WorldSID 50th RibEye YZ Range - Lower Ribs front, rear, and center LED positions

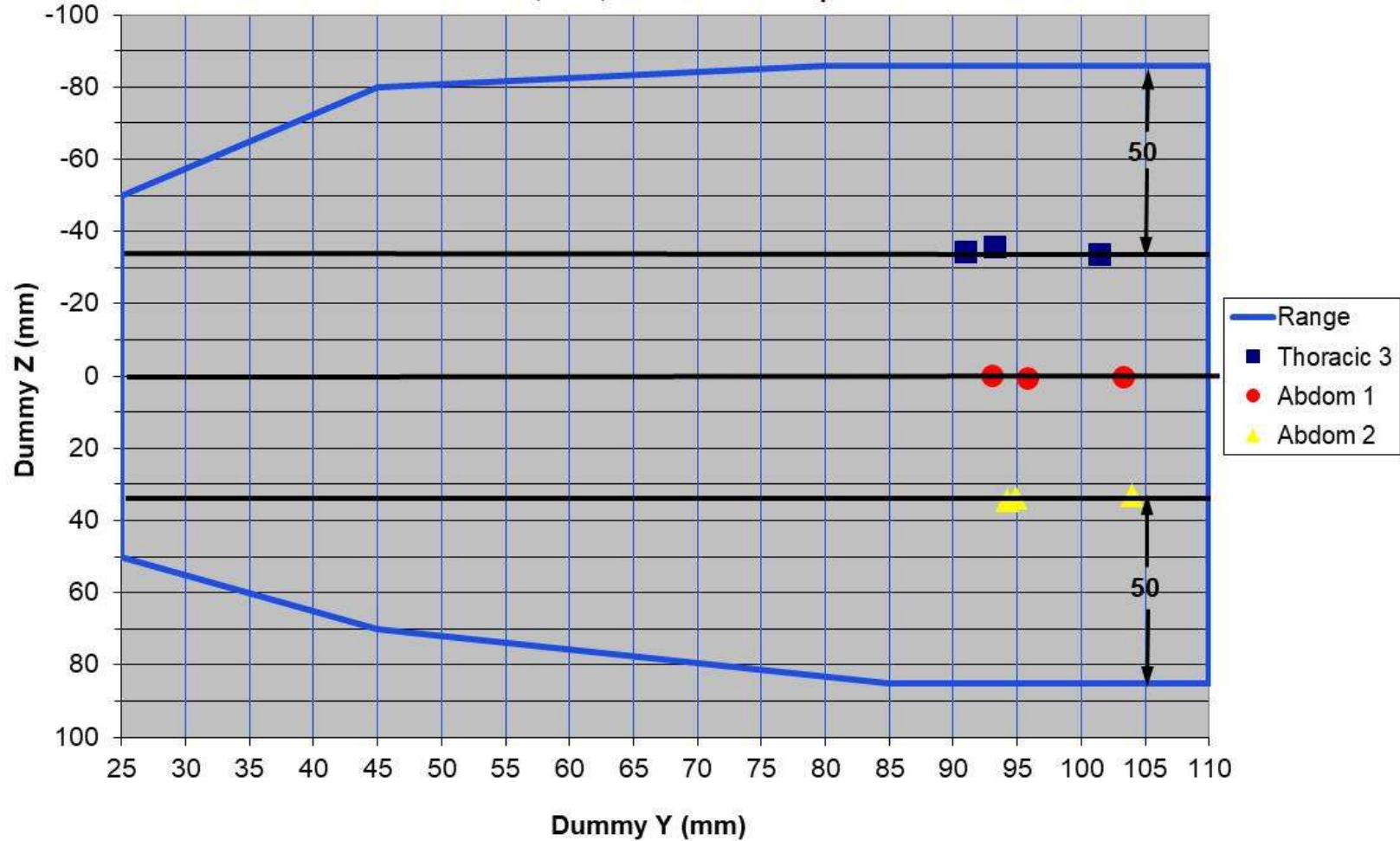

Figure A3. RibEye measurement range in Y-Z plane – lower three ribs

A-2. Power requirements

The RibEye model #60005 can be powered by a high-quality DC voltage source from 12 to 60 Volts. At idle, the RibEye draws 15 Watts. When collecting data, it draws 25 Watts typically and up to 40 Watts maximum if all LEDs are out of range and driven to full power.

When the batteries are fully charged, the backup battery pack can power the RibEye while collecting data for at least 20 minutes. After running the RibEye on batteries for 20 minutes, it will take about 2 hours to fully recharge the batteries.

The RibEye controller has a self-resetting polymer fuse on its power input. If this fuse ever opens, it can take up to 4 hours to self-reset.

There is no active cooling in the RibEye, so it should not be left powered on for more than 1 hour, or it might overheat and shut itself down to cool off.

A-3. Data acquisition and storage

Data is collected to RAM random-access memory and simultaneously in flash memory.

Sample rate: 10,000 samples per second per LED (10 kHz)

Modes: Linear or circular buffer

Total acquisition time: 3 minutes

Data storage: 3 minutes

A-4. Ethernet communication

Communication between the RibEye and the PC software is via 10/100 MBS Ethernet. The IP address can be set by the user. (Factory default = 192.168.0.240.)

Please refer to the RibEye Software User Manual 7.0 for software details and instructions on how to change the RibEye network's IP address. The software manual is included on the USB thumb drive shipped with the RibEye and can also be downloaded from our website, www.boxborosystems.com.

The RibEye communicates with the PC software using port 3000. An open protocol is used to send commands to the RibEye and to receive data. See the RibEye Communications Protocol document on our website for more information.

A-5. Trigger circuits

The trigger circuit can be configured for a variety of options including a high-impedance input or a lower impedance, optically isolated input. Please contact Boxboro Systems for your requirements. Appendix B shows standard cable assemblies available for connecting to typical DAS systems.

Figure A4 shows the generic trigger circuits inside the RibEye controller.

Figure A5 shows the trigger input configured for connection to an external DTS Distributor using Boxboro Systems cable #70110 and extension cable #70200.

Figure A6 shows the trigger input configured for a Kistler NXT32-supplied trigger using cable #70115 or Kistler KiDau/KiHub or Kistler DTI Hub using Boxboro Systems cable #70125.

Figure A7 shows the trigger input configured for generic pigtail cable assemblies using Boxboro Systems exit cable #70120 and breakout cable #70201.

Figure A8 shows a trigger switch wiring example for the generic pigtail assemblies.

A-6. Armed-out circuit

Boxboro Systems exit cable #70120 and breakout cable #70201 have an “Armed-out” signal that turns on when the RibEye is armed and turns off when the RibEye has completed storing the data for the test in flash memory.

Figure A9 shows the armed-out circuit.

Figure A10 shows an example of how to wire an indicator light to the armed-out circuit.

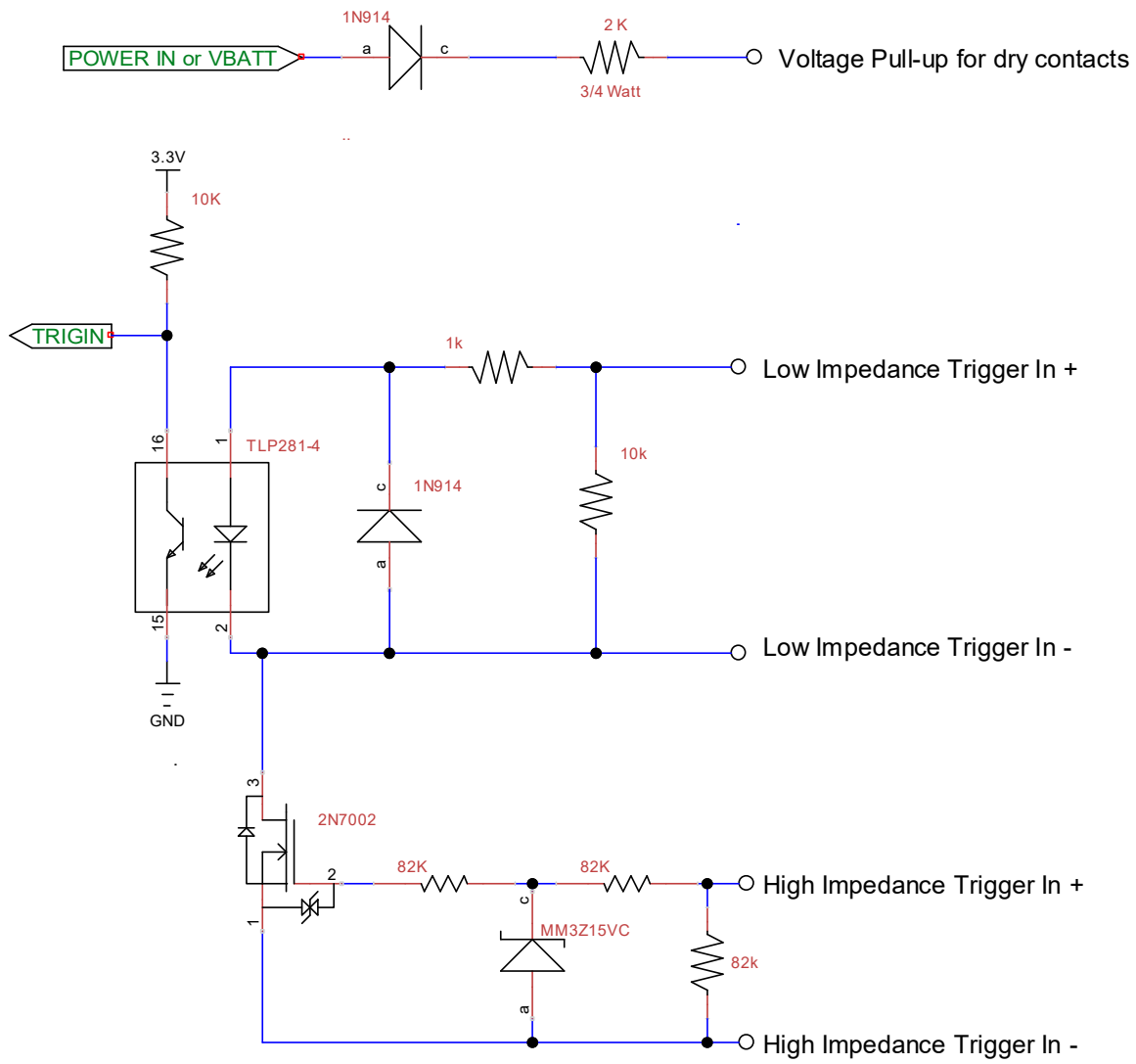

Figure A4. Trigger input circuits

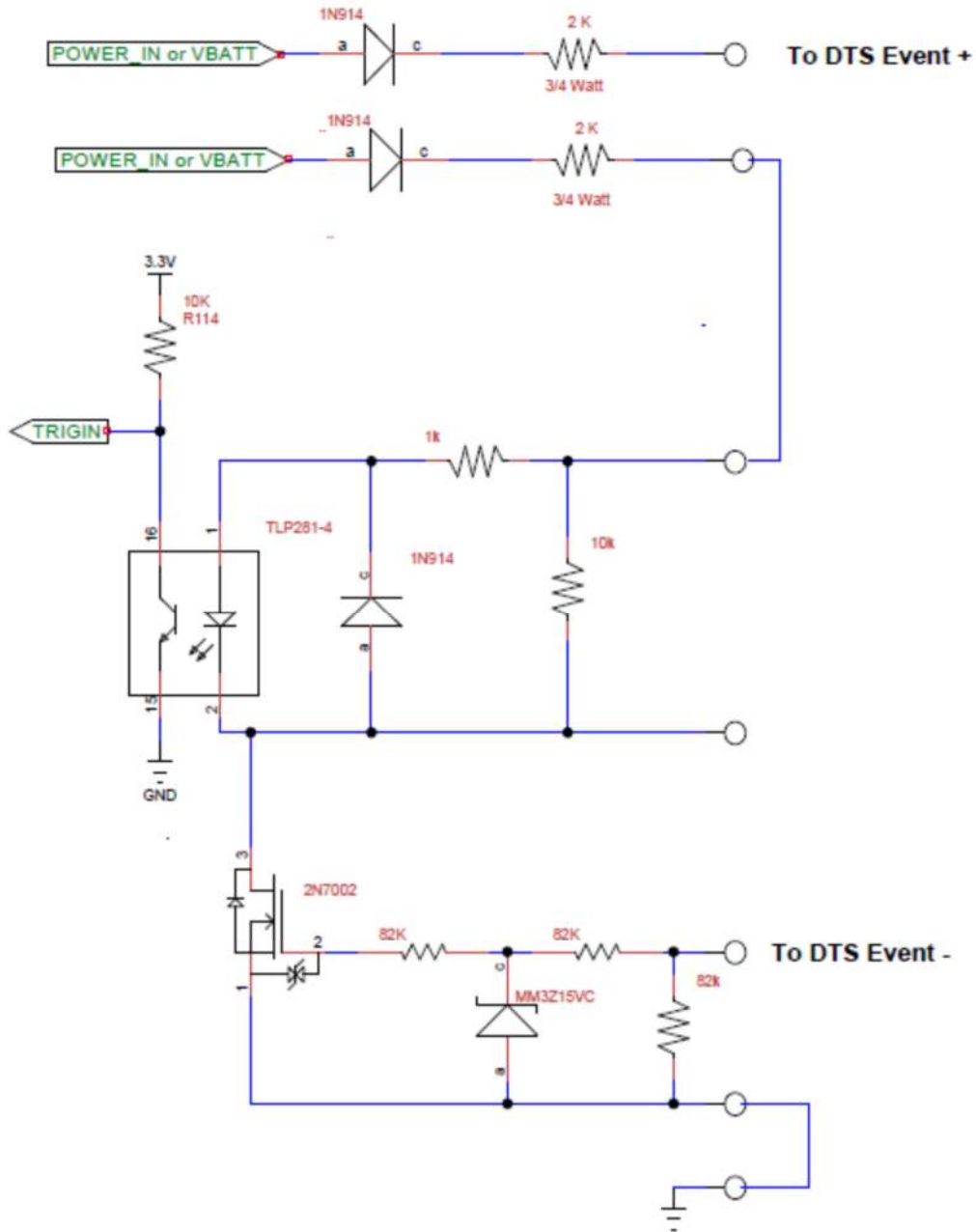

Figure A5. Trigger input configured for DTS MDB-supplied trigger
 (Note: Power-in and ground are supplied from the DTS MDB)

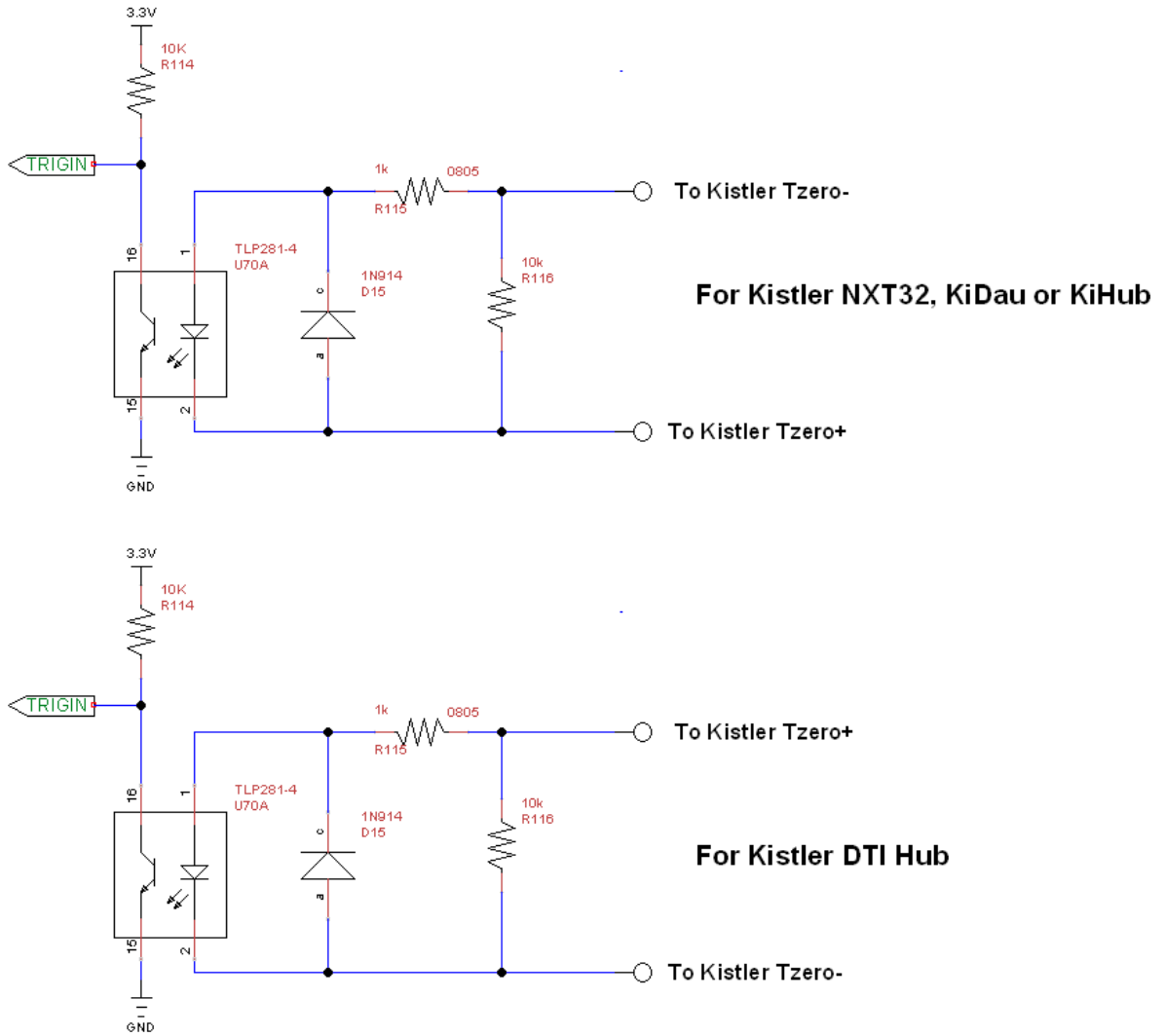

Figure A6. Trigger input configured for Kistler NXT32, KiDau, or KiHub (upper drawing) or Kistler DTI Hub (lower drawing)

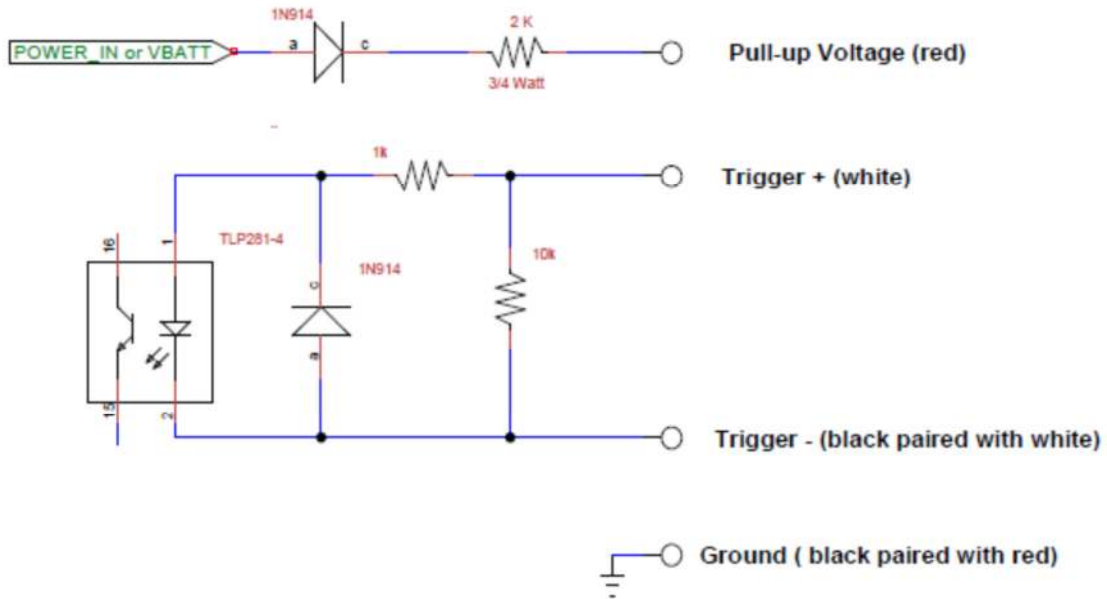

Figure A7. Trigger input configured for generic pigtail cable assemblies

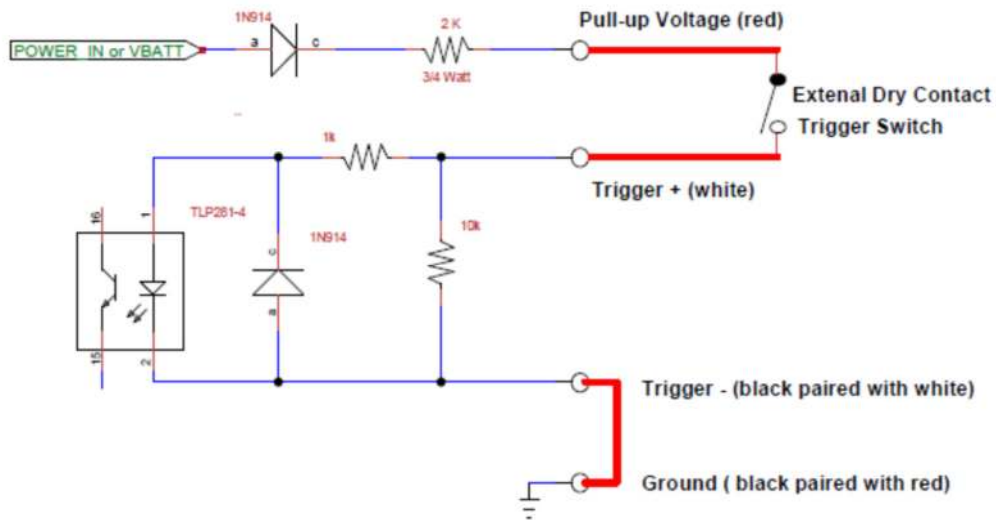

Figure A8. Trigger switch wiring example for generic pigtail cable assemblies

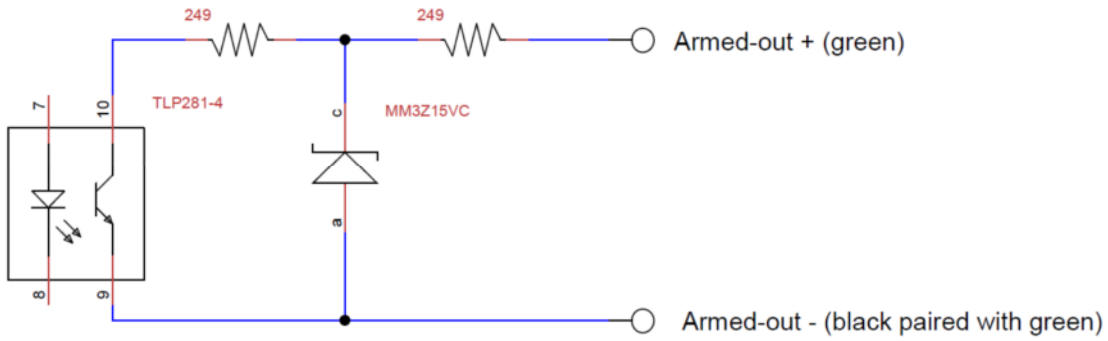

Figure A9. Armed-out circuit for generic pigtail cable assemblies

(Note: The opto-isolated output transistor turns on when the RibEye is armed and collecting or storing data)

WARNING: The maximum current through the circuit must be less than 20 milliamps.

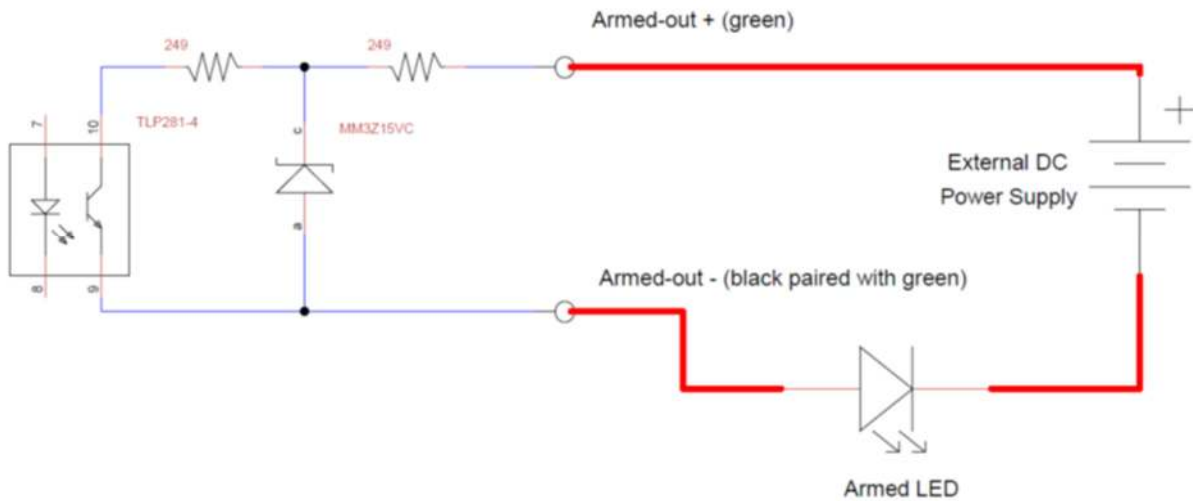

Figure A10. Example of armed-out indicator light wiring for generic pigtail cable assemblies

Appendix B. Cable assemblies for connection to various DAS Systems

Boxboro Systems provides several cable options to connect the WorldSID RibEye controller to the customer's equipment to get power, trigger, and Ethernet connections. You must specify the cable option you need when ordering the RibEye.

For customers with DTS TDAS G5 or Slice in-dummy DAS with external DTS Distributor (see Figure B1)

Exit cable #70110 connects to the RibEye controller at one end and to an extension cable #70200 at the other end. This cable set uses the RibEye high-impedance trigger input compatible with the DTS trigger output. With this cable the RibEye software trigger setting should be set to “Rising Edge”

Note: A DTS DBX cable to system port (DDX) – DTS cable #10700-00053 – can be used instead of the #70200 extension cable.

For customers with Kistler NXT32 in-dummy DAS (see Figure B2)

Exit cable #70115 connects to the RibEye controller at one end and at the other end, to the last NXT32 module in the chain of modules in the dummy. This cable uses the RibEye opto-isolated trigger input compatible with the Kistler CrashLink trigger. With this cable the RibEye software trigger setting should be set to “Rising Edge”

For customers with other types of internal or external DAS (see Figure B3)

Exit cable #70120 connects to the RibEye controller at one end and to a breakout cable #70201 at the other end. The breakout cable is terminated in pigtails for power, opto-isolated trigger, and an armed output. The Ethernet connection is a standard RJ45 plug for connecting to an Ethernet hub/switch. With this cable the RibEye software trigger setting depends on how the external switch is configured. If the external trigger switch is wired as shown in Figure A8, where the switch closes upon a trigger, RibEye software trigger setting should be set to “Rising Edge”. If the switch opens when a trigger occurs, set the software trigger setting to “Falling Edge”.

For customers with Kyowa DAS with external DIS-61A Junction Unit (see Figure B4)

Exit cable #70120 connects the RibEye controller at one end to a #70209 extension cable at the other end. The extension cable plugs into a Kyowa DIS-61A Junction unit, and has pigtails for an external power connection. With this cable the RibEye software trigger setting should be set to “Rising Edge”

For customers with Kistler External KiHub or KiDau (see Figure B5)

Exit cable #70125 connects the RibEye controller at one end to extension cable #70208 at the other end. The #70208 cable plugs into a KiHub or KiDau.. With this cable the RibEye software trigger setting should be set to “Rising Edge”

For customers with Kistler External DTI Hub (see Figure B6)

Exit cable #70125 connects the RibEye controller at one end to extension cable #70218 at the other end. The #70218 cable plugs into a DTI Hub. With this cable the RibEye software trigger setting should be set to “Rising Edge”

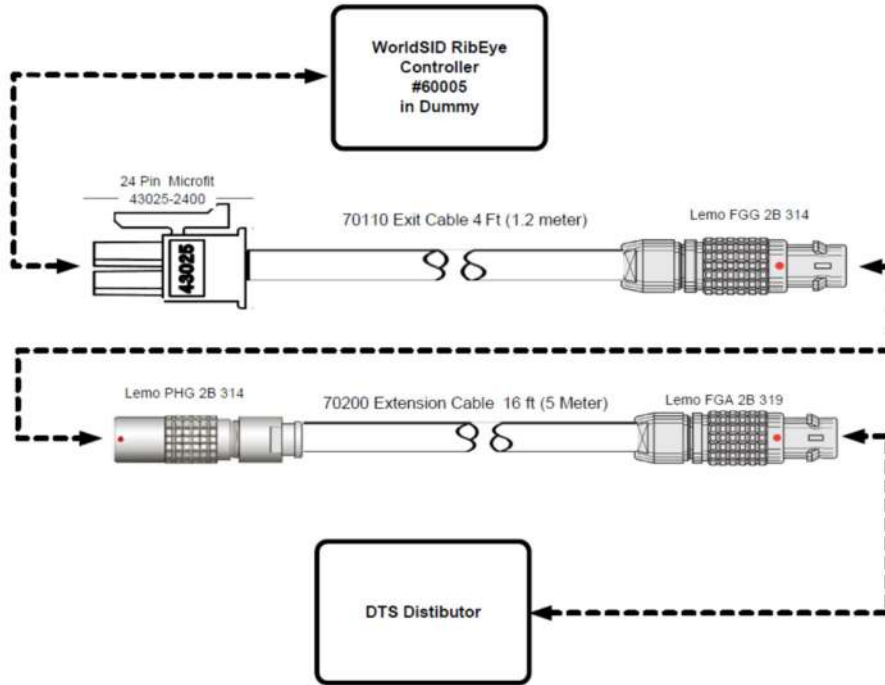

Figure B1. Cable option for DTS DAS – exit cable #70110 and extension cable #70200

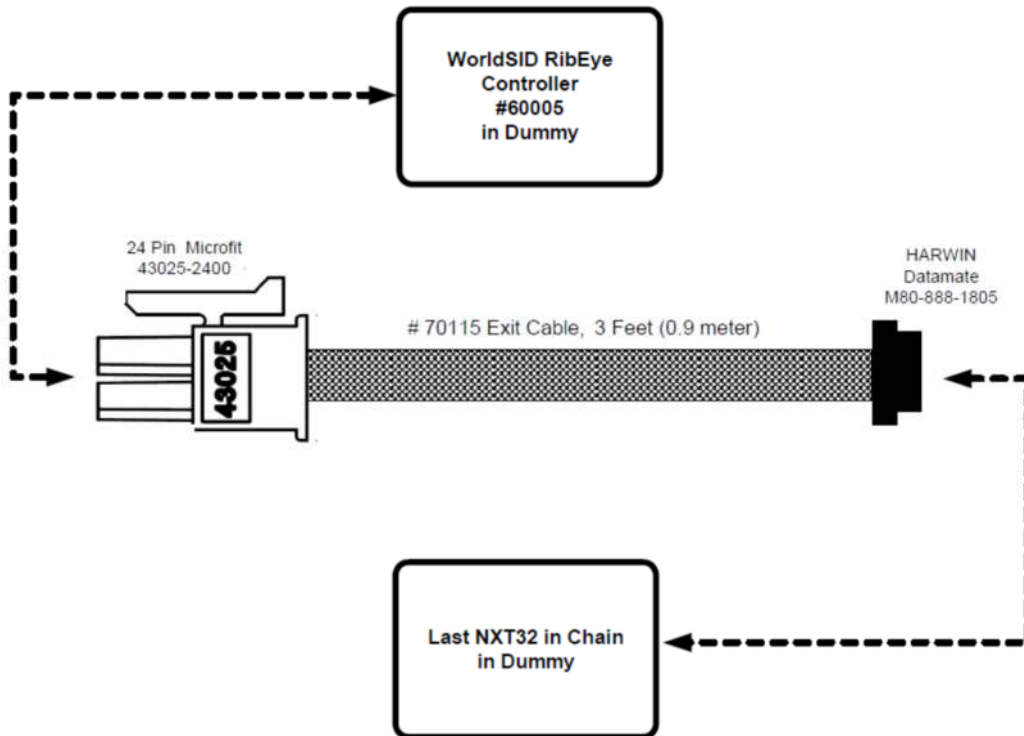

Figure B2. Cable option for Kistler NXT32 DAS – exit cable #70115

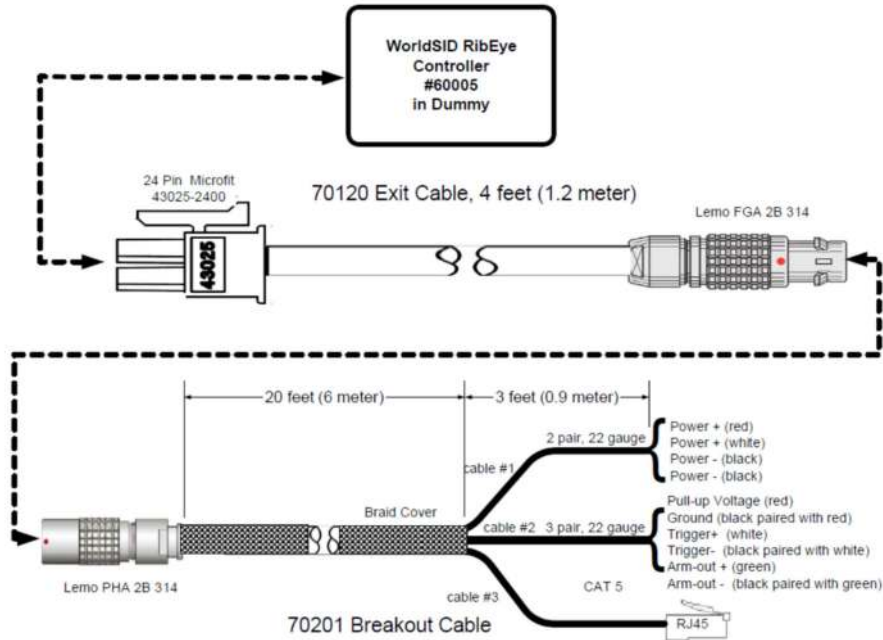

Figure B3. Cable option for generic DAS with exit and breakout cables – exit cable #70120 and breakout cable #70201 with opto-isolated trigger input and armed output

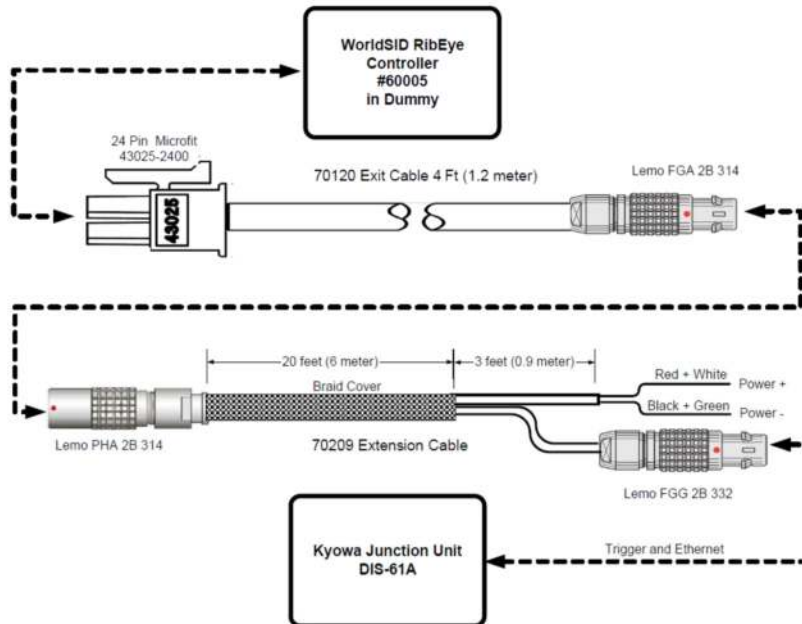

Figure B4. Cable option for Kyowa DAS – exit cable #70120 and extension cable #70209

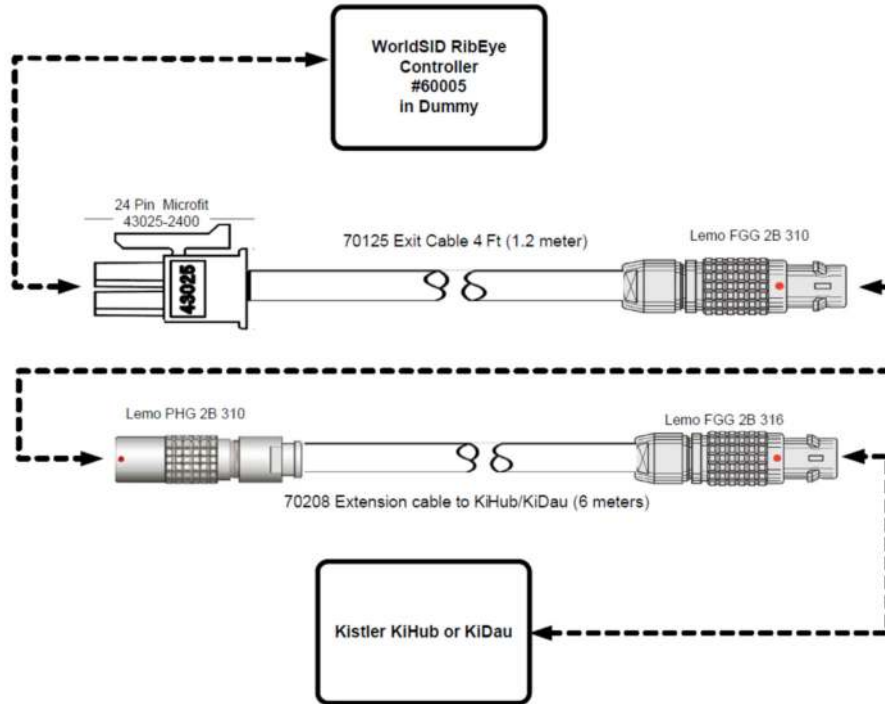

Figure B5. Cable option for Kistler KiHub/KiDau DAS – exit cable #70125 and extension cable #70208

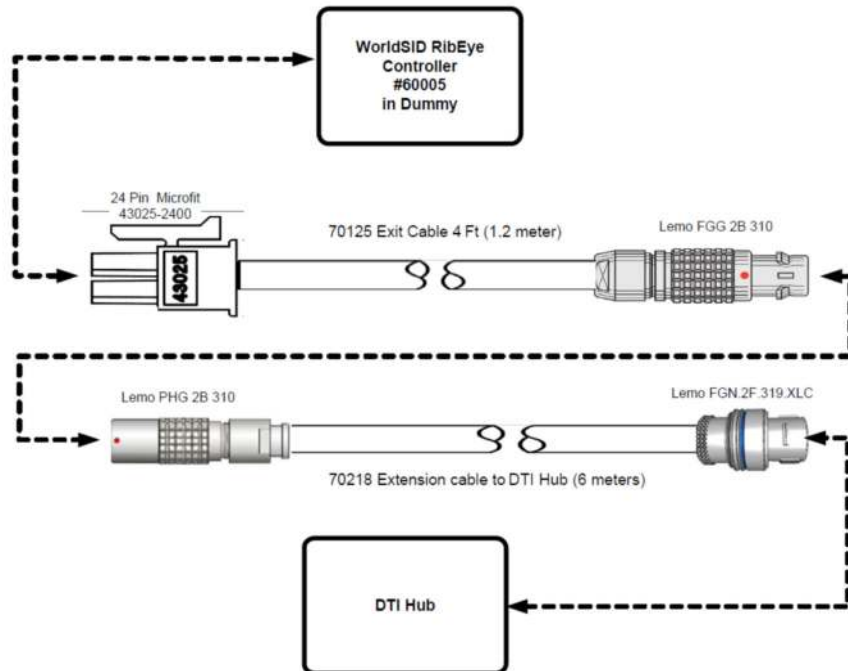

Figure B6. Cable option for Kistler DTI DAS HUB – exit cable #70125 and extension cable #70218

Appendix C. RibEye cable connector details

This section describes the connector wiring for the various RibEye cables to facilitate field-repair of damaged cables. All Molex Microfit 3.0 connectors are crimp types. We recommend using a Molex crimp tool designed for the Microfit 3 series. The current production hand crimp tool is Molex part #638190000.

C-1. LED cables

Table C1. LED cables #70031 and #70032

Microfit connector	43025-0600
Microfit crimp terminals	43030-0009 20-24 gauge

RibEye Name	Microfit 43025-0600
rear LED cathode	1
middle LED cathode	2
front LED cathode	3
rear LED anode	4
middle LED anode	5
front LED anode	6

View from mating side

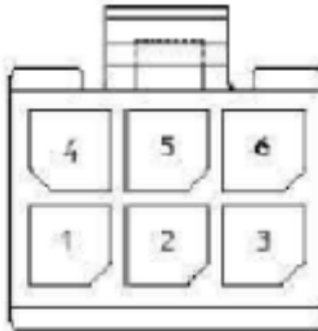

Anode

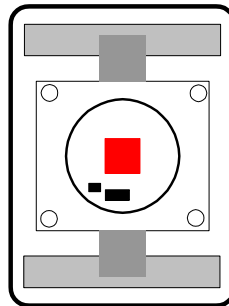

Cathode

C-2. LED breakout cable #70030

This cable has six 6-pole LED connectors that mate with #70031 and #70032 LED cables and a 20-pole connector that plugs into the controller “LED” Socket.

Table C2. Breakout cable LED connector (6)

Microfit connector s	43020-0600
Microfit crimp terminals	43031-0009 20-24 gauge

RibEye Name	Microfit 43020-0600	RibEye Name	Microfit 43020-0600
rear LED cathode	1	rear LED anode	4
middle LED cathode	2	middle LED anode	5
front LED cathode	3	front LED anode	6

View from mating side

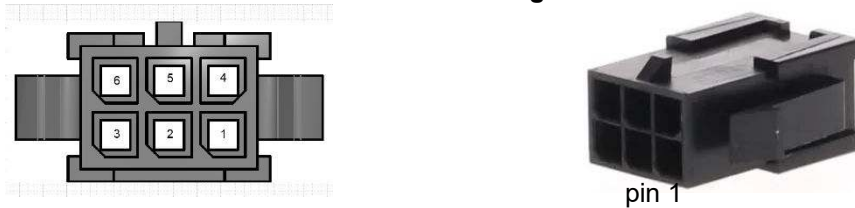

Table C3. Breakout controller connector

Microfit connector s	43025-2000
Microfit crimp terminals	43030-0009 20-24 gauge

RibEye Name	Microfit 43025-2000	RibEye Name	Microfit 43025-2000
shoulder rear	1	thorax 3 rear	11
shoulder middle	2	thorax 3 middle	12
shoulder front	3	thorax 3 front	13
thorax 1 rear	4	abdomen 1 front	14
thorax 1 middle	5	abdomen 1 middle	15
thorax 1 front	6	abdomen 1 front	16
thorax 2 rear	7	abdomen 1 front	17
thorax 2 middle	8	abdomen 1 middle	18
thorax 2 front	9	abdomen 1 front	19
GND - cathodes	10	GND - cathodes	20



C-3. Exit cable connector

The exit cable connector is defined below.

Table C4. Exit cable controller connector

Microfit connector s	43025-2400
Microfit crimp terminals	43031-0009 20-24 gauge

RibEye Name	Microfit 43025-2000	RibEye Name	Microfit 43025-2000
Ethernet Rx+	1	Ethernet Rx-	13
Ethernet Tx+	2	Ethernet Tx-	14
GND	3	GND	15
Vin Pullup 2	4	reserved for future use	16
5 V pullup	5	armed out -	17
reserved for future use	6	reserved for future use	18
reserved for future use	7	armed out+	19
Vin Pullup 1	8	GND	20
Lo I Opto Trig in +	9	LO I Opto Trig in -	21
Hi I Trig in +	10	HI I Trig in -	22
GND	11	GND	23
+Vin	12	+Vin	24



C-4. Sensor cable connector

The sensor cables are hard-wired to the sensors. A 7-pin Lemo 0B is used at the controller end of the cable.

Table C5. Sensor cable #70051

Name	Wire Color	Lemo FGG.0B.307.CLAD31
common	blue	1
out B	orange	2
out A	brown	3
-5 V	green	4
+5 V	red	5
control	yellow	6
ground	black	7
shield	shield	no connect