



HARDWARE USER MANUAL
RibEye™ Multi-Point Deflection Measurement System
for the Hybrid III ATD – 5th Female 2-Axis RibEye



Boxboro Systems LLC
978-257-2219
www.boxborosystems.com

Table of Contents

	<u>Page</u>
1.0 Overview	5
2.0 Mounting the RibEye	10
2.1 Controller mounting.....	13
2.2 Installation and removal of the controller connector and cable.....	13
2.3 Sensor head mounting.....	19
2.4 LED mounting.....	19
Angled vs. flat LEDs.....	19
LED mounting procedure.....	20
2.5 Plugging LED cables into connector blocks.....	27
2.6 Interface/trunk box mounting.....	27
3.0 Operating the RibEye	29
3.1 Status light and manual arming.....	29
3.2 RibEye IP address.....	29
3.3 LED flashing on power up.....	29
3.4 RibEye error codes.....	30
4.0 RibEye Software	31
5.0 RibEye Maintenance	35
Appendixes	
A RibEye specifications.....	36
A.1 Accuracy and measurement range.....	36
A.2 Power requirements.....	41
A.3 Data acquisition and storage.....	41
A.4 RibEye coordinate system.....	41
B Cable assemblies.....	44
B.1 Controller cable.....	44
B.2 Power input cable.....	47
B.3 Trigger cable.....	49
B.4 LED cables.....	50
B.5 Cable assemblies for connecting to DAS.....	53
C Trigger inputs and armed output circuits.....	54

List of Figures and Tables

<u>Figure No.</u>		<u>Page</u>
1	RibEye components.....	6
2	Front view of spine.....	7
3	Rear view of spine.....	8
4	Interface/trunk box	9
5	Interface/trunk box with cables	9
6	Diagram for mounting RibEye components.....	11
7	Detailed view of RibEye components to be mounted	12
8	RibEye controller connector and cable	13
9	Install or remove screws that clamp the connector to the controller.....	14
10	Pull the connector out with the lanyard after removing screws	15
11	Pop the connector from its mate inside the controller using a screwdriver to lever the connector upward	16
12	Connector popped out of the controller and ready to be removed	17
13	Controller in back of spine after connector and cable have been removed.....	18
14	LED radiation pattern.....	19
15	Rib with double-stick foam tape in place.....	20
16	LED and angled mounting block.....	21
17	LED snapped into angled mounting block.....	21
18	Flat LED in place on rib with lead wire secured by nylon tie.....	22
19	Angled LED in place on rib with lead wire secured by nylon tie	22
20	Heat-shrink sleeve in place over flat LED	23
21	Heat-shrink sleeve in place over angled LED	23
22	Applying heat to shrink the sleeve and secure the LED tightly to the rib.....	24
23	Flat LED in place after heat-shrinking.....	25
24	Angled LED in place after heat-shrinking	25
25	Flat LED and lead wire installed.....	26
26	Angled LED and lead wire installed	26
27	LED connector blocks on RibEye sensor heads, rear view of spine.....	27
28	Interface/trunk box	28
29	Main software screen for Hybrid III 5th Female.....	32
30	Data plotting screen for Hybrid III 5th Female	33
31	Data export screen for Hybrid III 5th Female	34
A1	RibEye measurement range and typical accuracy, Rib 1 X axis.....	37
A2	RibEye measurement range and typical accuracy, Rib 1 Y axis.....	38
A3	RibEye and dummy X and Z axes.....	42
A4	RibEye Y and Z axes.....	43
B1	RibEye controller cable and connector	44
B2	Controller cable, Lemo connector end details.....	45
B3	Controller cable, Microfit end details.....	46
B4	Power cable from RibEye trunk box	47
B5	Power cable details.....	48
B6	Trigger cable from RibEye trunk box	49

List of Figures and Tables, continued

<u>Figure No.</u>	<u>Page</u>
B7	50
B8	51
B9	51
B10	52
B11	52
B12	53
C1	55
C2	56
C3	57
C4	58
C5	58
C6	59
C7	60
<u>Table No.</u>	<u>Page</u>
A1	36
A2	39
A3	39
A4	39
A5	40
A6	40
A7	41
C1	54

HARDWARE USER MANUAL
RibEye™ Multi-Point Deflection Measurement System
for the Hybrid III ATD – 5th Female 2-Axis RibEye

1.0 Overview

The RibEye measurement system as designed for this ATD (anthropomorphic test dummy) has the following components, shown in Figure 1:

- Two sets of six LEDs (total of 12), which are mounted on the ribs.
- Two optical sensor heads, which derive the position of the LEDs during RibEye operation.
- Two LED connector blocks, which are built into the sensor heads.
- The RibEye controller, which is mounted inside the back of the spine.
- A 5th Female spine modified per J2915 for mounting the RibEye:
 - The spine's tapered mounting bolts prevent the spine from rocking on the Thorax adaptor
 - Holes in the spine lighten its weight
- The interface box, which is also called the trunk box because it is usually placed in the trunk of the vehicle.

Appendix A provides detailed specifications for the RibEye, including accuracy, measurement range, and power requirements.

Figure 1. RibEye components

A = LEDs; B = sensor heads; C = LED connector blocks; D = controller; E = spine; F = interface/trunk box

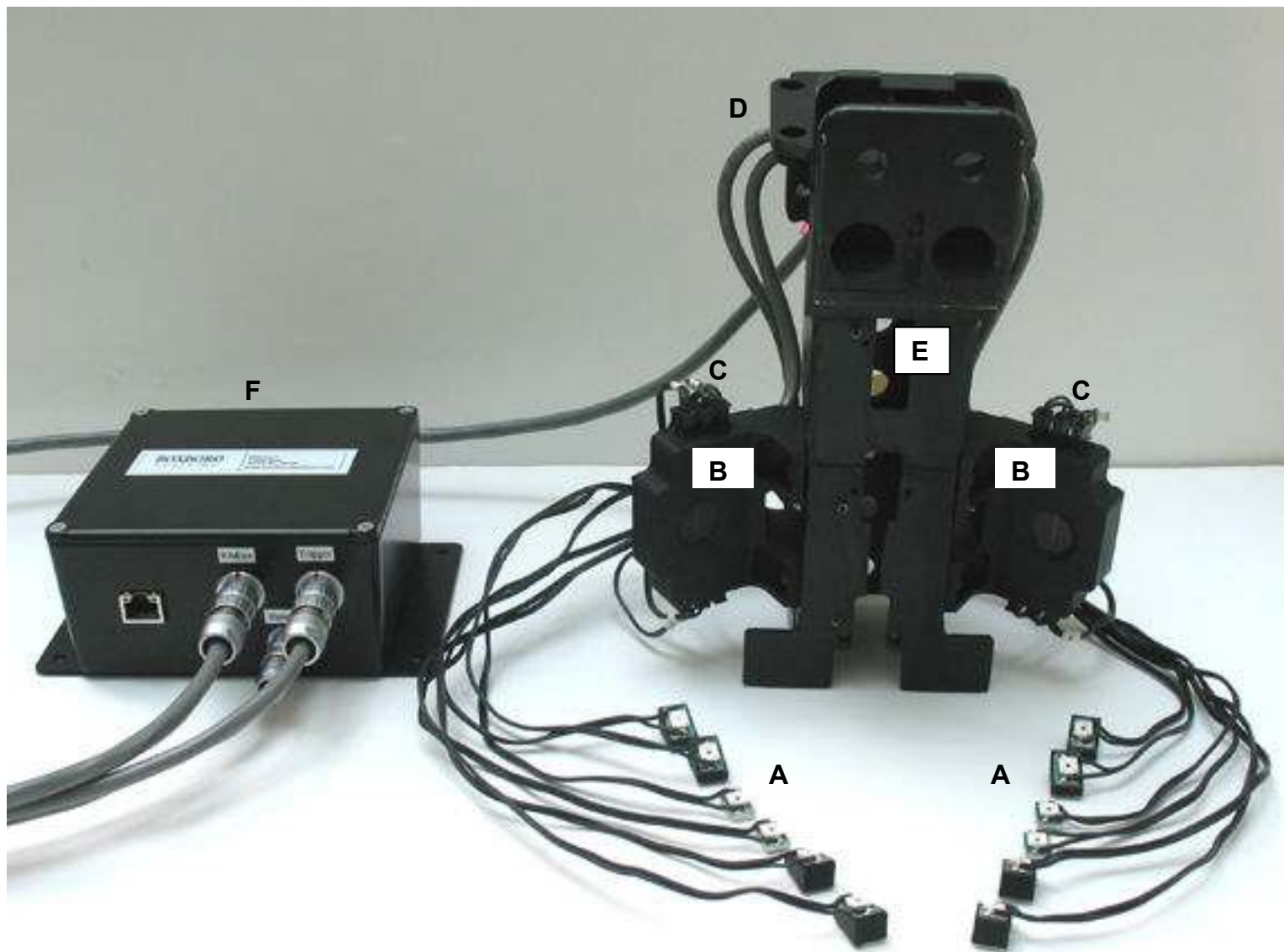

Front and rear views of the spine (Figures 2 and 3) show the sensor heads, LED connector blocks, and controller location in greater detail. The interface/trunk box has sockets for the RibEye controller, power input, and trigger cables (Figures 4 and 5). Appendix B contains more information on cable assemblies.

Figure 2. Front view of spine
A = sensor heads; B = LED connector blocks

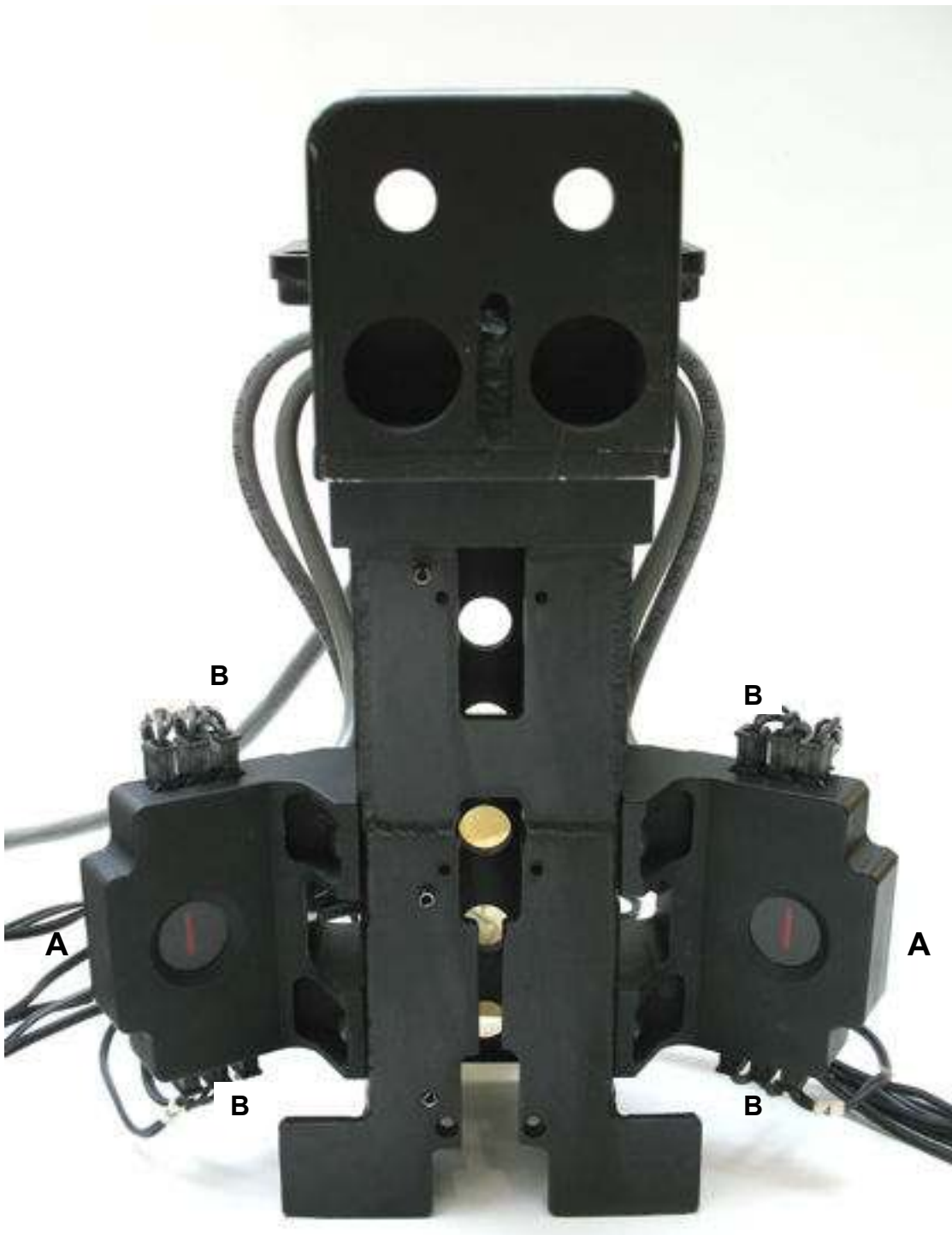

Figure 3. Rear view of spine

A = controller;
B = controller mounting screws;
C = RibEye controller connector and cable to trunk box;
D = controller connector screws;
E = LED connector blocks

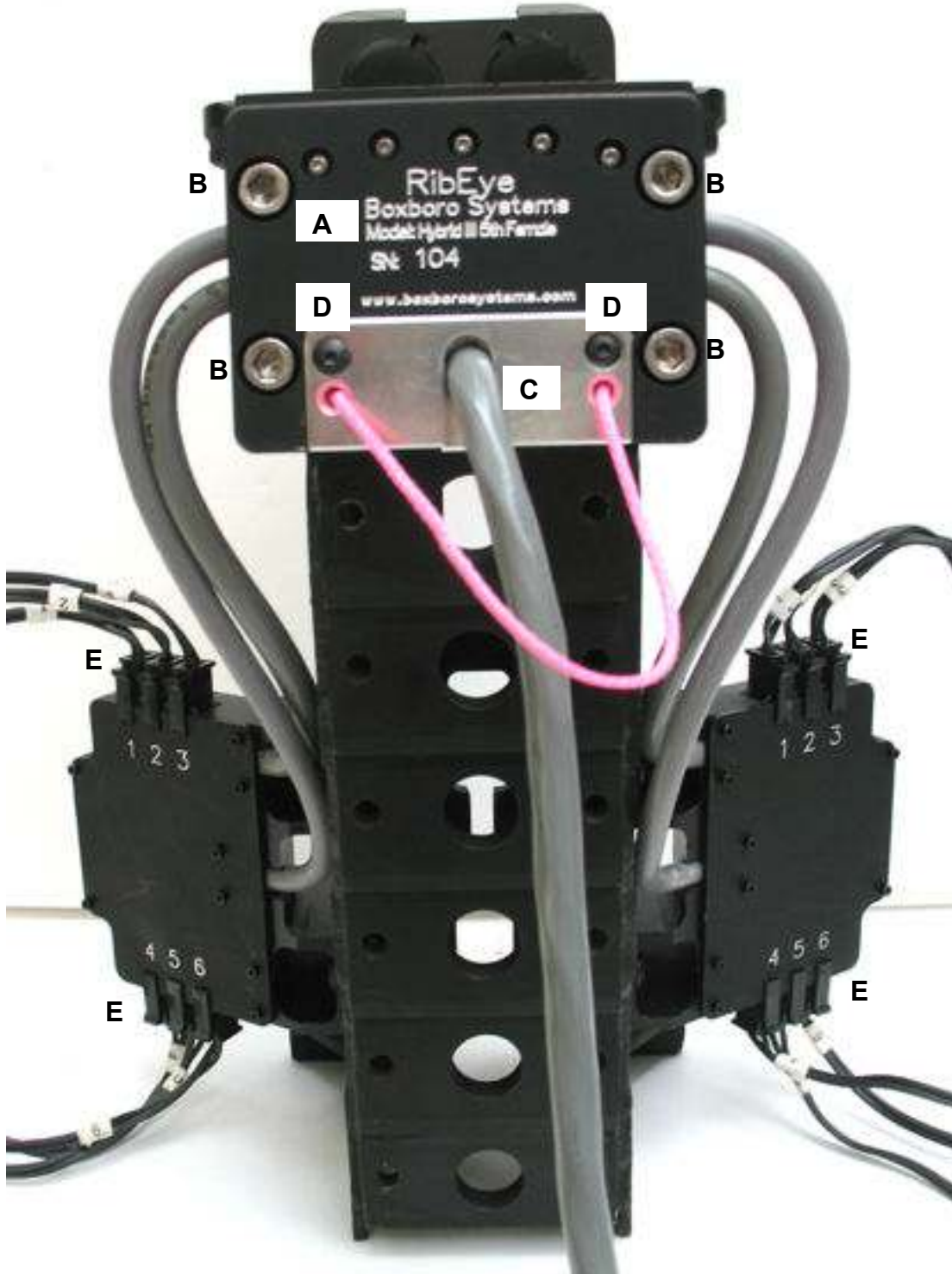
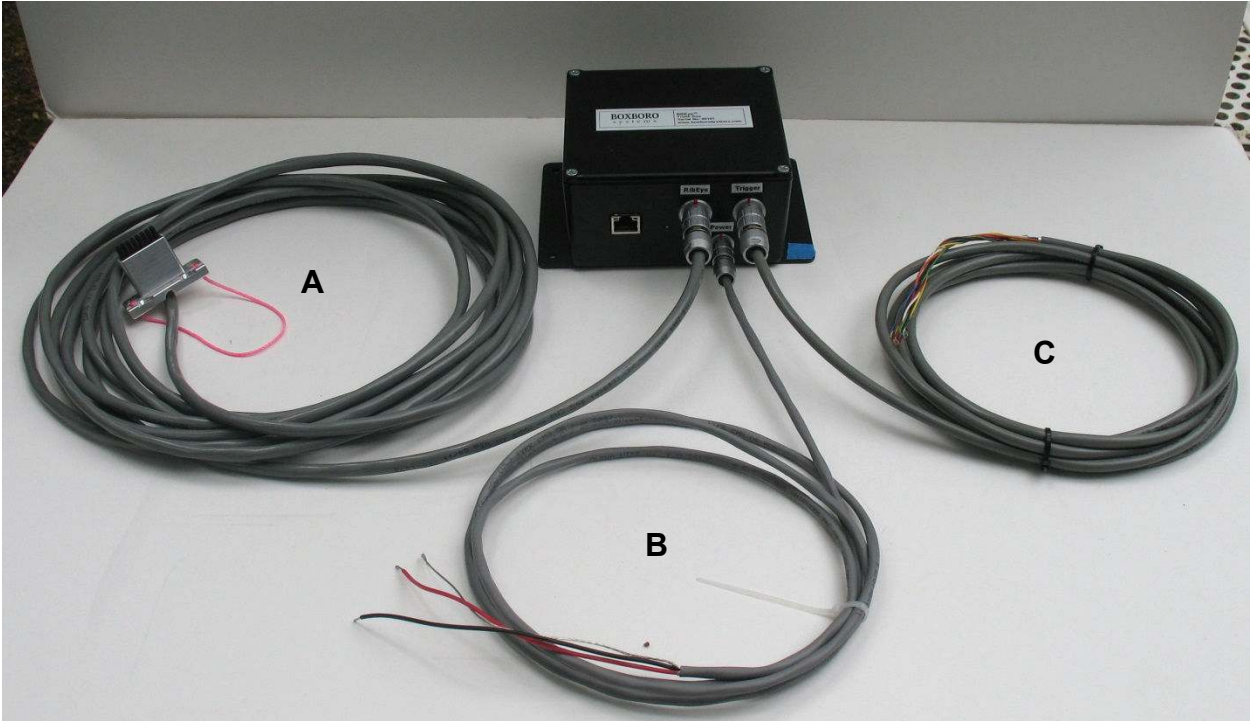

Figure 4. Interface/trunk box



Figure 5. Interface/trunk box with cables
A = RibEye controller cable; B = power cable; C = trigger cable



2.0 Mounting the RibEye

Diagrams for mounting the RibEye controller and sensor heads are shown in Figures 6 and 7. The following mounting instructions are specific to the 5th Female 2-axis RibEye for the Hybrid III ATD.

The first step is to remove the existing ATD spine, as follows:

- First remove the neck mount from the original spine, along with the neck and head
- Then remove the shoulder and arms from the original spine
- Next remove the sternum plate, then the ribs
- To release the spine from the Thorax adaptor, remove the six 5/16 x 18 socket-head cap screws (SHCS)
- Finally, remove the chest potentiometer assembly from the bearing on the spine mounting weldment. The reason for this is that the chest pot arm can move between a LED and a sensor, blocking the light and causing the data to drop out (see section 3.4, RibEye error codes).

After the existing spine is removed, follow these basic steps to install the dummy's new spine and RibEye. Note that the controller and sensor heads must be mounted to the spine *before* assembling the ribs onto the spine.

- Use the six tapered 5/16 x 18 bolts to mount the new spine onto the Thorax adaptor
- Install the RibEye controller and sensor heads (details in sections 2.1–2.3 below)
- Mount the LEDs on the ribs (details in section 2.4 below)
- Assemble the ribs onto the spine in this order: 6-5-4-1-2-3
 - As each rib is installed, plug in the rib's LEDs to the LED connector blocks *before* installing the next rib (details in section 2.5 below)
 - Tie back any excess LED cable behind the sensors
- Install the neck mount with neck and head, the shoulder assembly, and the arm assembly to the new spine.

Figure 6. Diagram for mounting RibEye components

1 = controller; 2 = left sensor head; 3 = right sensor head; 4 = four screws for mounting controller (socket-head cap #10-32 x 5/8);
5 = eight screws for mounting sensor heads (button-head cap #10-32 x 1/4)

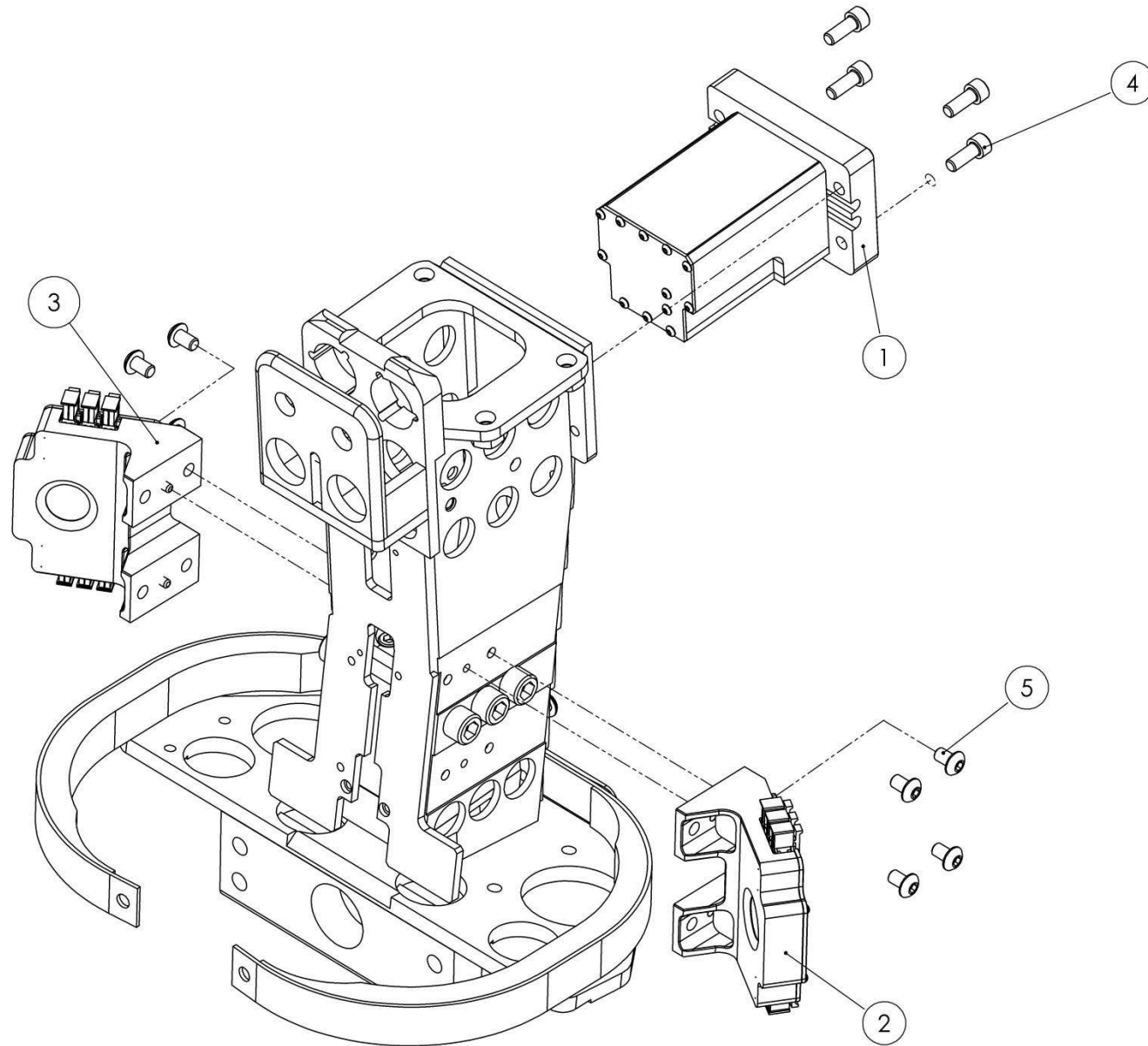

2.1 Controller mounting

The controller slides into the back of the spine and is attached with four 10-32 x 5/8 socket-head cap screws (see Figure 3-B and Figure 6).

2.2 Installation and removal of the controller connector and cable

The RibEye controller connector (Figure 8) plugs into the back of the controller and is kept in place by two 4-40 x 5/8 button-head cap screws (Figure 3-D). The communications cable runs out of the controller and then down under the dummy skin (jacket) to exit at the bottom of the dummy skin. The cable is routed to the interface/trunk box. This cable cannot be installed until the rest of the RibEye has been installed in the dummy.

Figure 8. RibEye controller connector and cable

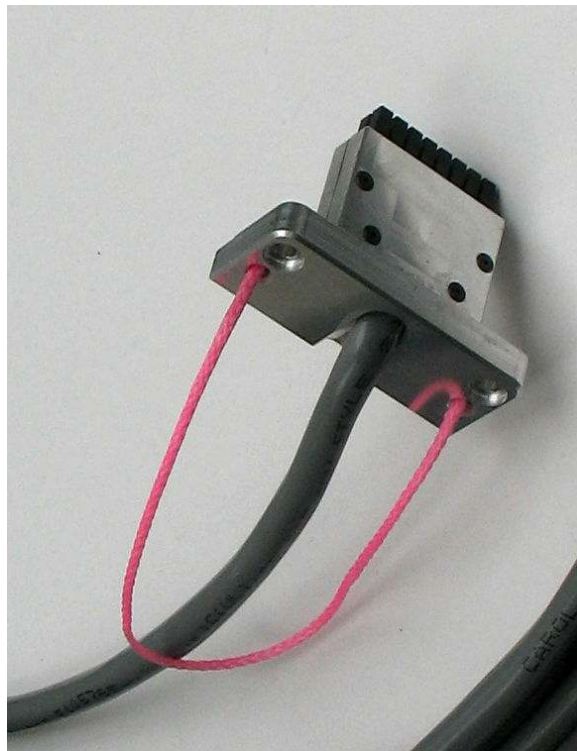

To install the controller cable, insert the connector into the controller and use an Allen wrench to tighten the two #4-40 screws, as shown in Figure 9.

To remove the connector and cable after a test, first remove the screws, then pull on the pink lanyard, as shown in Figure 10. This will pop the connector out from its mating connection inside the controller.

Alternatively, you can use a flat-head screwdriver to pop the connector out. Insert the screwdriver into the slots on the bottom of the connector as shown in Figure 11. Then twist the screwdriver to lever the connector out (Figure 12).

After the connector has been popped out, it can be pulled out of the controller safely. **DO NOT PULL ON THE CABLE ITSELF.** Figure 13 shows the back of the spine with the controller connector and cable removed.

Figure 9. Install or remove screws that clamp the connector to the controller

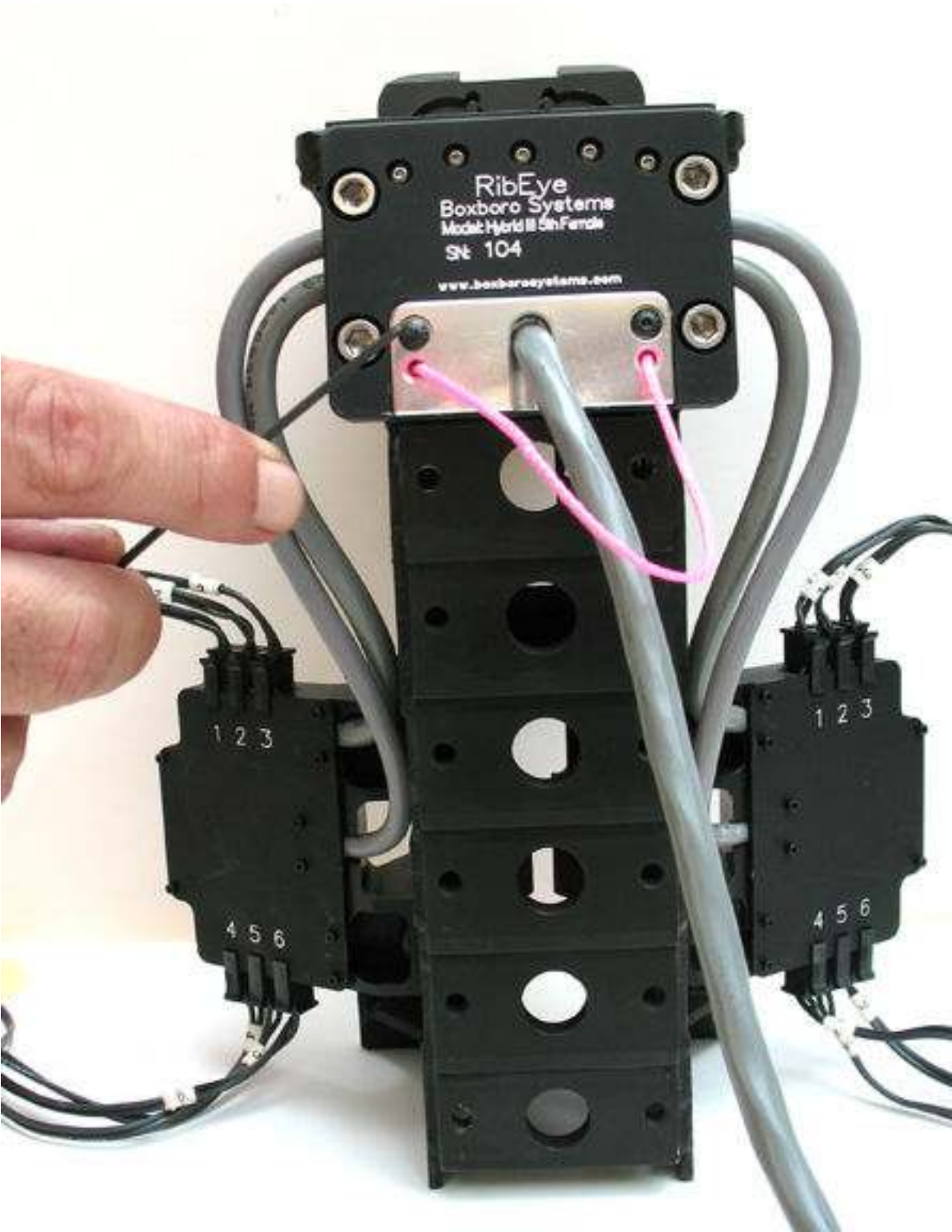

Figure 10. Pull the connector out with the lanyard after removing screws

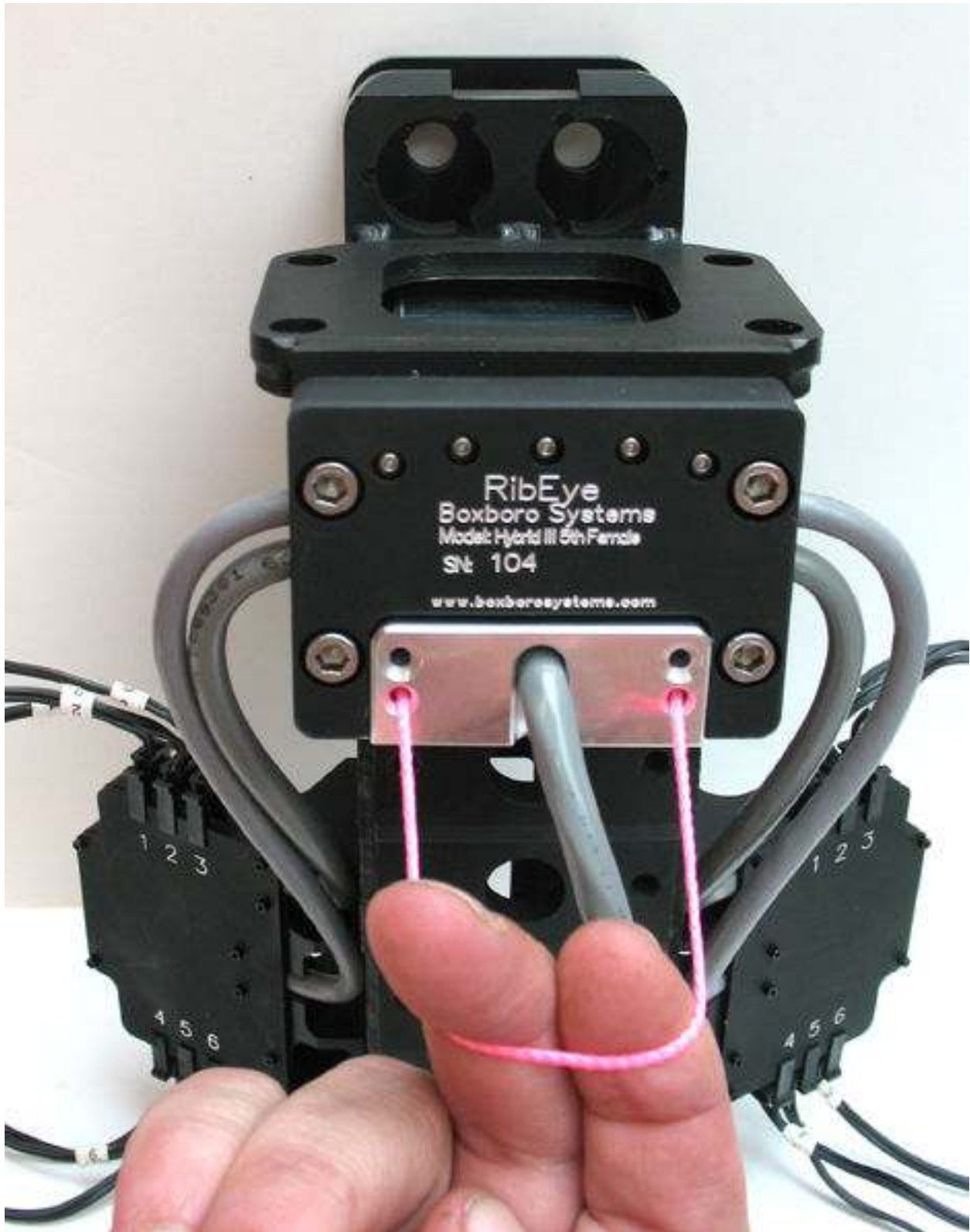

Figure 11. Pop the connector from its mate inside the controller using a screwdriver to lever the connector upward

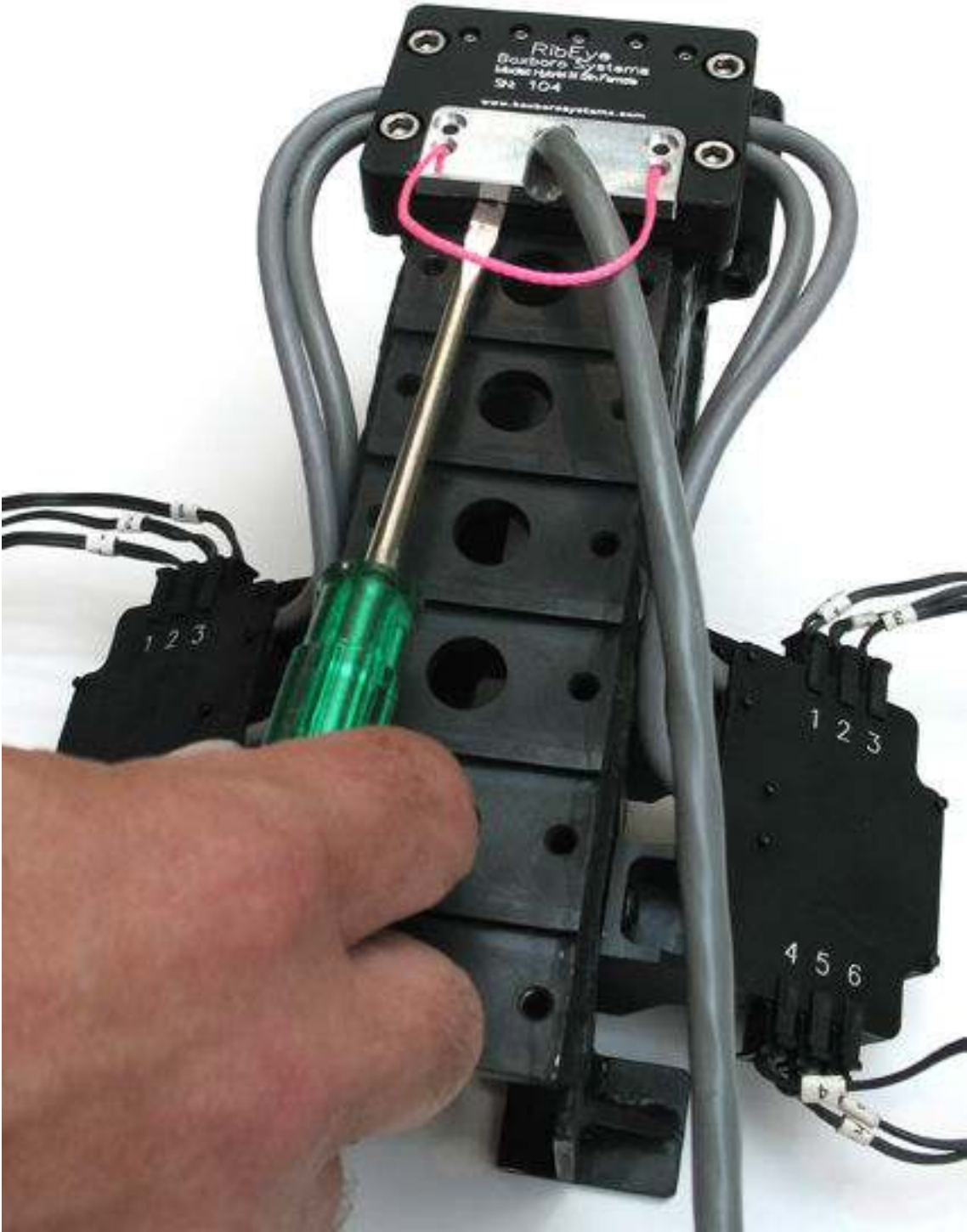

Figure 12. Connector popped out of the controller and ready to be removed

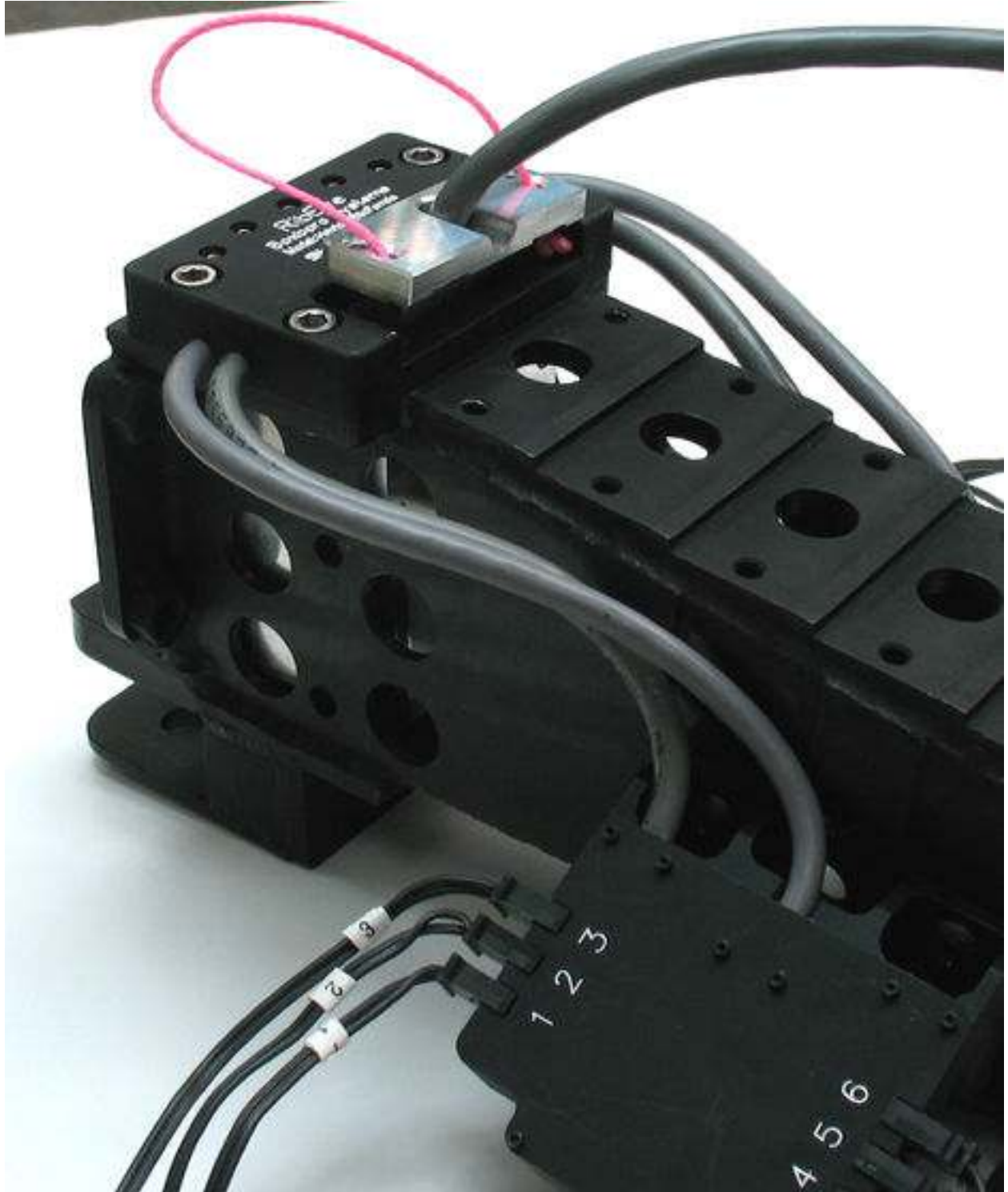

Figure 13. Controller in back of spine after connector and cable have been removed



2.3 Sensor head mounting

The two optical sensor heads are mounted to the left and right sides of the spine. Each sensor head is attached to the spine with four 10-32 x 1/4 button-head cap screws, as shown in Figures 6 and 7. Note that the spine has alignment pins that fit into precision holes in the sensor heads. The sensor heads also contain built-in connector blocks for the LED cables to plug into. Section 2.5 and Appendix B.4 provide more details on the LED cables.

2.4 LED mounting

The LEDs should be mounted to the ribs before the ribs are assembled onto the spine. The top rib is Rib 1, and the bottom rib is Rib 6. Left and right refer to the dummy's left and right sides. The LED cables and connector blocks are marked 1–6 for Ribs 1–6. **DANGER:** *The LEDs are very bright when driven at full power. Never look directly at the LEDs when they're turned on.*

Angled vs. flat LEDs

Some of the LEDs use angled mounting blocks that aim the LED toward the sensor head to provide the maximum amount of light to the sensors while minimizing power requirements. The LEDs on Ribs 3 and 4 are installed flat, directly onto the rib surface. The LEDs on Ribs 1, 2, 5, and 6 are mounted on angled blocks, which are then installed on the rib surface.

Figure 14 shows the radiation pattern of the LEDs, which explains why angling them improves their performance. Note that the brightest light is directly in front of the LED (on axis), and the brightness gets lower at larger angles. The RibEye controller continuously adjusts how hard it drives the LEDs to get a good signal to the sensors.

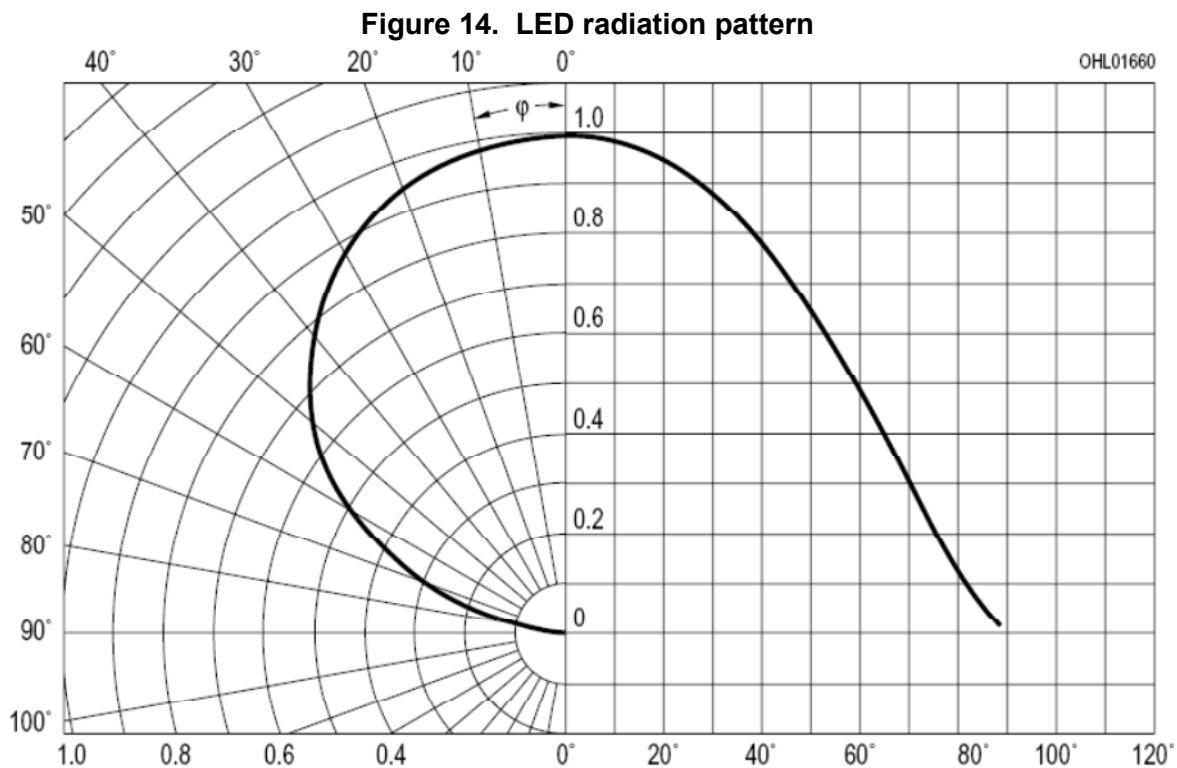

The RibEye uses different calibration curves to process the LED data, depending on which rib that the LED is mounted on (that is, its Z-axis location up or down). To obtain the guaranteed accuracy, the LEDs should be plugged into the connectors numbered for the rib they are attached to. The LED on Rib 1 plugs into connector #1, the LED on Rib 2 plugs into connector #2, etc.

If the light from a LED to a sensor head is blocked, the position reading will be invalid. If the dummy instrumentation uses a chest potentiometer, the chest pot arm can often block light from the LEDs to the sensors, causing error codes. If you need to run a test with a chest pot, we recommend that the arm be painted flat black to minimize reflections. The test operator can also adjust the positions of the LEDs on the ribs to minimize blockage from a chest pot arm. Please see section 3.4 below for more information on error codes.

LED mounting procedure

For best performance, the LEDs should be mounted between ± 55 mm and ± 60 mm in the dummy Y direction from the centerline of the sternum, or approximately 70 mm along the curve of the ribs from the centerline of the sternum. This places the LEDs near the tip of the rib, just before the rib thickness increases.

To begin mounting the LEDs, first use isopropyl alcohol to clean the damping material where the LEDs will be mounted on the rib's inner surface. Next, cut two pieces of double-stick foam tape, 3M VHB #4952 (which is supplied in the RibEye package). Each piece should be about 8-10 mm long. Stick the tape to the rib just inside of the rib's thick portion (Figure 15). Apply 30 PSI of force to the tape to ensure that it sticks well. Then peel off the paper on the other side, leaving a sticky surface prepared for the LEDs.

Figure 15. Rib with double-stick foam tape in place



As noted earlier, the LEDs on Ribs 3 and 4 are installed flat, directly onto the rib surface. The LEDs on Ribs 1, 2, 5, and 6 are mounted on angled blocks, which are then installed on the rib surface.

- For flat-mounted LEDs, first clean the back surface of the LED with alcohol, then apply the LED directly to the sticky tape on the rib
- For angle-mounted LEDs, first clean the back surface of the mounting block with alcohol, then snap the LED into the mounting block (Figures 16 and 17) and apply the angle block to the sticky tape on the rib. If the LED is loose in the block, you can use super-glue (cyanoacrylate) to glue the LED to the angle block.
- Press the LED or mounting block onto the tape with at least 30 PSI of force to ensure a good bond
- Tightly secure the LED cables to the ribs using nylon ties.

Figures 18 and 19 show flat and angled LEDs stuck to the ribs.

Figure 16. LED and angled mounting block

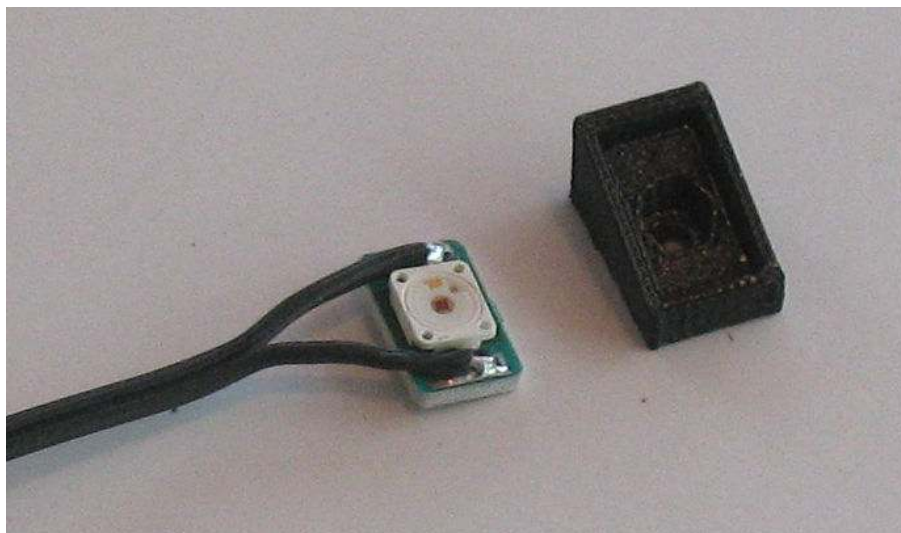

Figure 17. LED snapped into angled mounting block

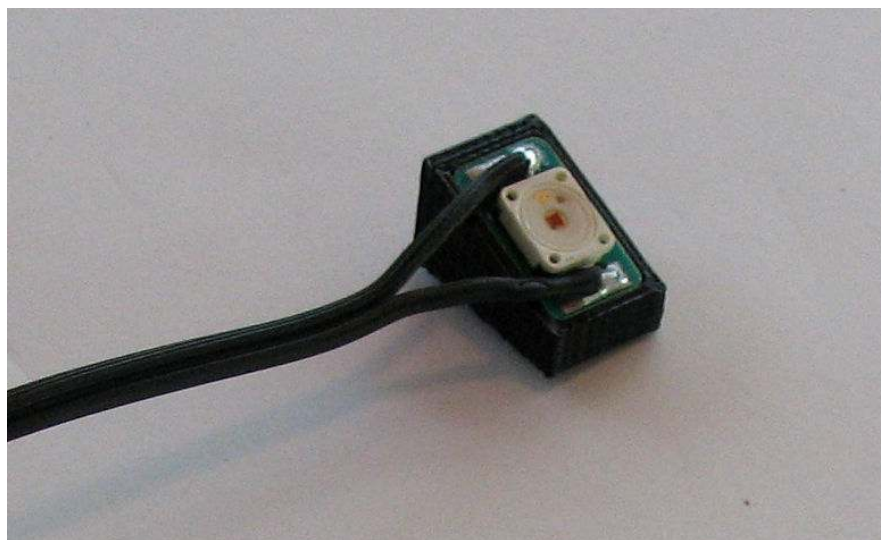

Figure 18. Flat LED in place on rib with lead wire secured by nylon tie



Figure 19. Angled LED in place on rib with lead wire secured by nylon tie



The next step is to further secure the LEDs onto the ribs using “sleeves” of heat-shrink tubing (which are included in the RibEye package). The heat-shrink tubing is standard 1-inch-diameter polyolefin with a 3:1 shrink ratio and a full shrink temperature of 100°C (212°F). To expose the LED to light, holes are already cut out of the sleeves using a standard 0.25-inch (6.35-mm) paper hole punch. The heat-shrink tubing supplied with the RibEye is made by Qualtek, part number Q2-F3x-1-01-MS50FT for a 50-foot reel. **NOTE:** *Do not use glue-lined heat-shrink tubing, because the glue can bubble out of the hole and get on the front of the LED.*

The first step here is to slide a heat-shrink sleeve over the LED, centering the hole directly over the red dot in the center of the LED (Figures 20 and 21).

Figure 20. Heat-shrink sleeve in place over flat LED

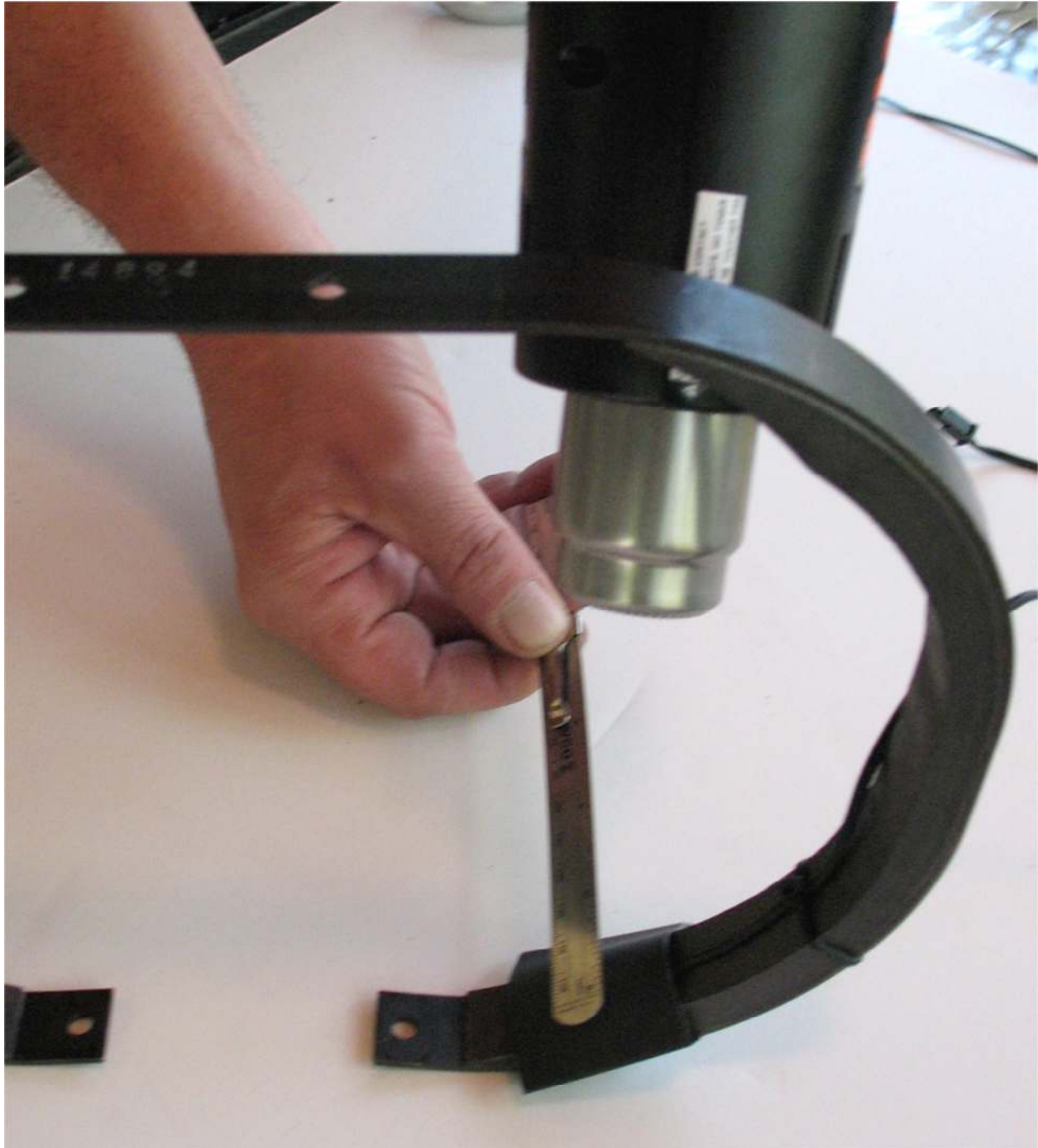

Figure 21. Heat-shrink sleeve in place over angled LED



When the heat-shrink sleeves are positioned, use a heat gun to apply heat to the front of the sleeve while shielding the LED with a flat metal device such as a ruler (Figure 22), then apply heat to the back of the sleeve. For a tight fit, be sure to eliminate bubbles in the sleeve material.

Figure 22. Applying heat to shrink the sleeve and secure the LED tightly to the rib



Return to the front of the sleeve and apply heat gently without shielding the LED. Stretch the round hole with your finger so that it fits around the square edge of the LED. It need not be perfectly aligned, but extra materials are supplied in case your first attempt is unsuccessful. Figures 23 and 24 show flat and angled LEDs after heat-shrinking. Figures 25 and 26 show the ribs with installed LEDs and lead wires.

Figure 23. Flat LED in place after heat-shrinking



Figure 24. Angled LED in place after heat-shrinking



Figure 25. Flat LED and lead wire installed



Figure 26. Angled LED and lead wire installed

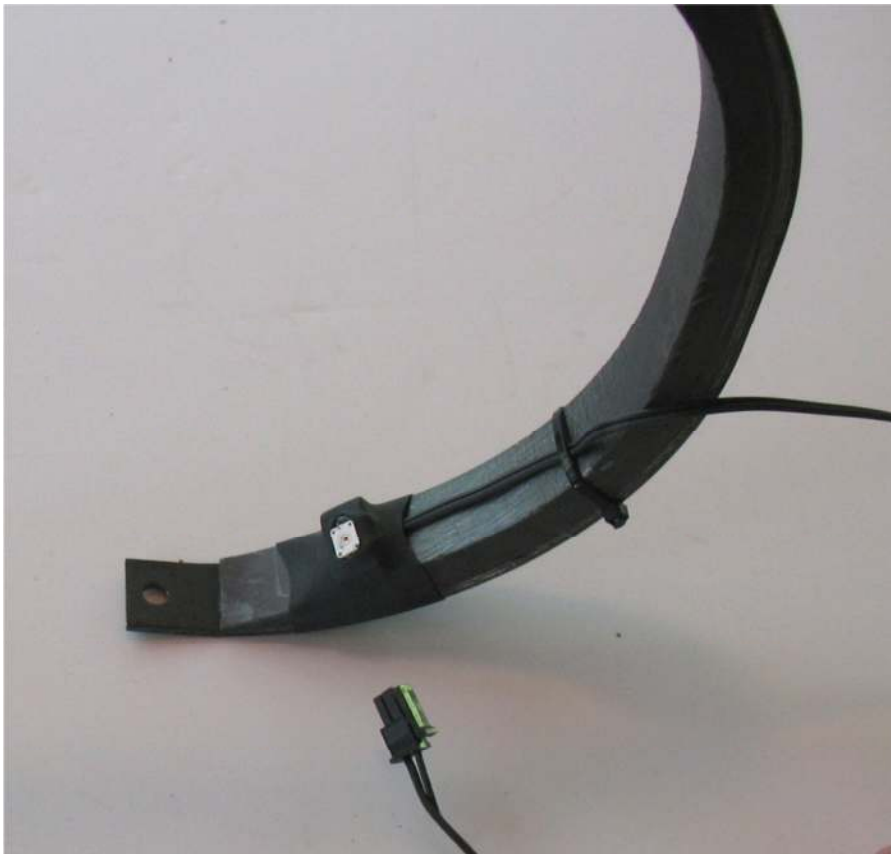

2.5 Plugging LED cables into connector blocks

Once the LEDs are in place and their lead wires (cables) secured tightly to the ribs, the ribs can be assembled onto the dummy spine, and the other end of the LED cables can be plugged into the LED connector blocks on the top and bottom of the RibEye sensor heads. The connections are marked with numbers that correspond to the rib numbers, 1–6, left and right (Figure 27). Appendix B provides more detail on the LED cable assemblies.

NOTE: *All loose LED lead wires/cables must be gathered and restrained to prevent them from entering the sensors' field of view and blocking the light between the LEDs and the sensors. This causes error codes, as described above for chest pot arms. See section 3.4 below for more information on error codes.*

Figure 27. LED connector blocks on RibEye sensor heads, rear view of spine

A = spine (rear); B = left LED connector block and sensor head;
C = right LED connector block and sensor head

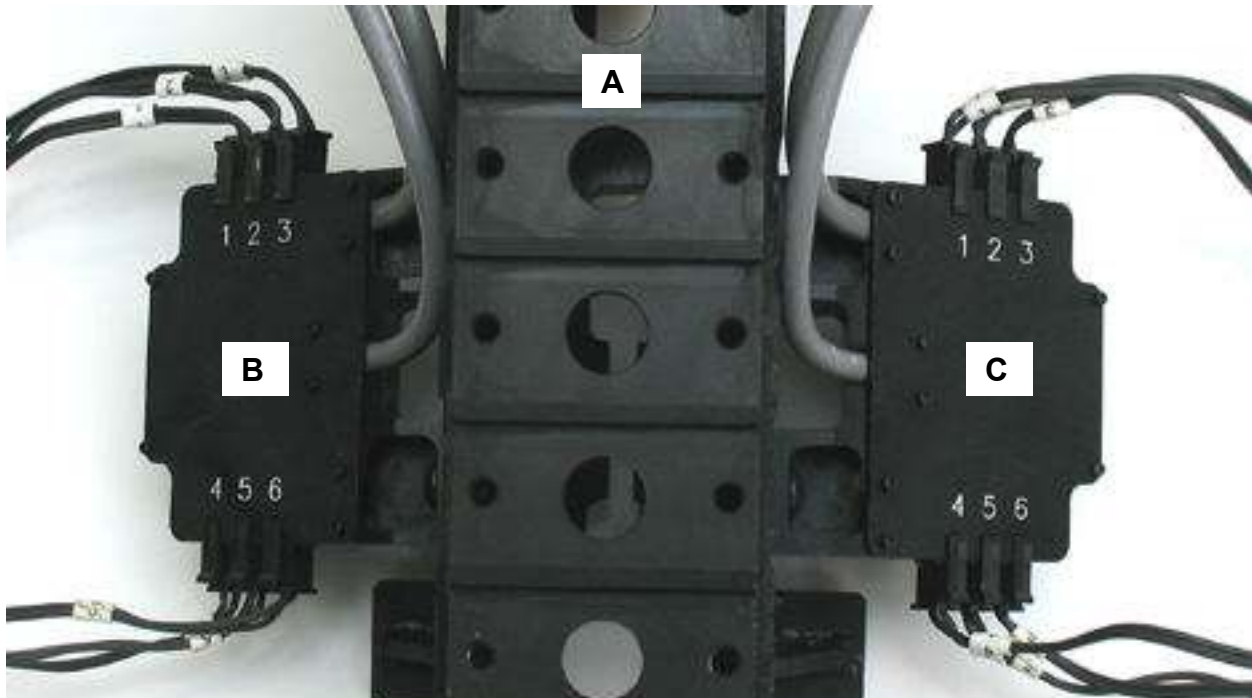

2.6 Interface/trunk box mounting

The interface/trunk box is intended to be mounted in the trunk of the vehicle, near the power source. Four holes are provided on the base of the box for mounting. The trunk box can be mounted in any orientation, but we recommend that it be mounted such that the side of the box with all of the connectors is easily accessible.

The RibEye communications cable from the controller in the spine is connected to the jack on the trunk box labeled “RibEye” (Figure 28). Jacks and pigtail cables are also provided for incoming power and trigger connections. The power cable should be connected to a DC power source. Appendix A.2 lists the RibEye’s power requirements, and Appendix B provides details on all cable assemblies).

Important: *The incoming power plug acts as a power switch for the interface/trunk box and the RibEye. Always unplug the power connector before plugging in or unplugging the communications cable to the RibEye controller.*

Figure 28. Interface/trunk box
A = Ethernet connection; B = status light

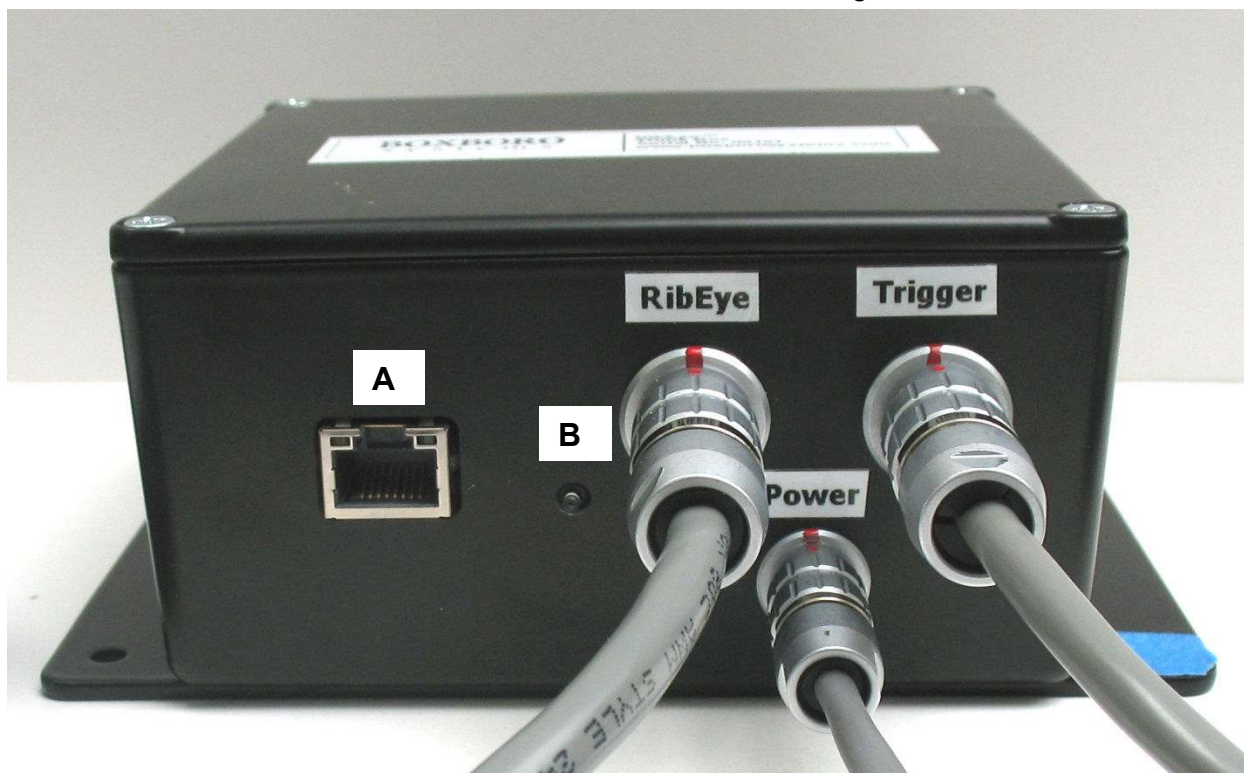

The trigger cable is used to provide a trigger input to the RibEye. Appendix C contains the trigger connector pinouts and trigger circuits. An Ethernet cable is used to connect the trunk box either to a router/hub or directly to a laptop PC. The status light indicates whether the RibEye is idle or busy acquiring data (see section 3.1, Status light and manual arming).

3.0 Operating the RibEye

The RibEye operates as a stand-alone smart sensor that acquires and stores data. A PC program is used to control the RibEye, download data, and export data in standard formats. Please refer to the RibEye Software User Manual for details on how the PC program functions. This software manual is included on a disk with the RibEye package, or you can access it on our website at <http://www.boxborosystems.com/servicepage.html>. Updates to the RibEye PC software can be downloaded from the website as they become available.

The RibEye has a published control protocol, and some manufacturers of data acquisition systems have added RibEye control to their DAS software. Please contact Boxboro Systems for more information.

Important: *As noted earlier, the power plug on the RibEye trunk box acts as a power switch for the RibEye. Always wait to plug in the power connector until after all of the other cables are plugged in, and always remove the power connector before removing any of the other cables.*

3.1 Status light and manual arming

The status light on the interface/trunk box blinks at different rates depending on what the RibEye is doing:

- 0.5 Hz = idle with data in memory
- 1.0 Hz = idle with memory erased
- 2.0 Hz = acquiring data
- 5.0 Hz = storing data in flash memory
- 10 Hz = erasing flash memory

The status light also functions as a push-button that can be used to manually arm the RibEye when it is idle and the memory is erased. To manually arm the RibEye, you must hold the status light button pushed down for at least 3 seconds.

3.2 RibEye IP address

The RibEye ships from the factory with its IP address set to 192.168.0.240. This IP address can be changed to work with your LAN (local area network). You can change the RibEye IP address directly from the RibEye software using the “Find RibEyes” button on the main screen. Alternatively, you can communicate with the RibEye directly using a PC, without connecting to a LAN. To connect a PC directly to the RibEye, your PC must be set up with a fixed IP address on the same subnet as the RibEye. For instructions on how to view and change the RibEye IP address, please refer to the RibEye Software User Manual.

3.3 LED flashing on power up

When the RibEye is powered on, it will flash each LED for about 1 second. The LEDs will flash in the following order:

1. Rib 1 Left
2. Rib 2 Left
3. Rib 3 Left
4. Rib 4 Left
5. Rib 5 Left
6. Rib 6 Left

7. Rib 1 Right
8. Rib 2 Right
9. Rib 3 Right
10. Rib 4 Right
11. Rib 5 Right
12. Rib 6 Right

3.4 RibEye error codes

If the RibEye cannot accurately calculate a LED position, it will generate error codes in the data file, causing a drop-out in the plots. The RibEye will force the X and Y data to the same error code. Error codes can be generated in three potential situations:

1. Light from a LED is blocked between the LED and one of the sensors
2. A LED moves out of the RibEye's range, so that the LED cannot send enough light to the sensor
3. Too much ambient light exists to accurately resolve the LED's position.

The error codes are outside the range of normal RibEye operation – that is, Y cannot be under 10 or greater than 120.

For 2-axis systems, the X and Y data will be forced to –

- 1 if the left sensor (dummy's left) is blocked or sees too much ambient light
- 2 if the right sensor (dummy's right) is blocked or sees too much ambient light
- 3 if both sensors are blocked or see too much ambient light
- 327 if a divide-by-zero condition occurred in the data processing.

Error codes will be generated whenever the RibEye begins to operate outside of its measurement range. The RibEye's measurement range is defined in Appendix A.1.

If an error code occurs, you must discount the data for a few milliseconds before and after the drop-out in the plots. As noted above in section 2.4, the cause of a drop-out is usually a loose cable that swings between the LED and the sensors, blocking the light, or a chest pot arm that swings between the LED and sensor (usually Rib 6). A drop-out can also occur in the 5th Female dummy if the lap belt forces the dummy's abdomen insert up into the rib cage, blocking the LEDs on ribs 6 and 5, which generally occurs when the dummy submarines under the lap belt.

In all of these cases, before and after the light is completely blocked, the obstacle reflects light, which confuses the sensor and causes bad data to be reported. That's why a few milliseconds of data must be discounted before and after the blockage and drop-out.

NOTE: The error codes can get masked by filtering the data. Therefore, we strongly recommend reviewing and saving a copy of the unfiltered data so that the error codes are preserved.

4.0 RibEye Software

For instructions on how to install and operate the RibEye's PC software, please refer to the latest version of our Software User Manual. As noted above, this software manual is included on a disk with the RibEye package, or you can access it on our website at <http://www.boxborosystems.com/servicepage.html>. Updates to the RibEye PC software can be downloaded from the website as they become available.

For the Hybrid III 5th Female RibEye connected to a dummy, the main software screen (Figure 29) allows you to –

- Connect and disconnect from the RibEye
- View the RibEye status
- Find RibEyes on your network and change their IP addresses
- Change the trigger setting
- Show the current LED positions
- Control data acquisition (linear or circular buffer, amount of data to collect, etc.)
- Erase memory
- Download data and select the amount of data to download
- Arm the RibEye (if memory is erased).

The 5th Female's data plotting screen (Figure 30) allows you to –

- View downloaded or previously collected test data
- Show plots with –
 - All of the X channels
 - All of the Y channels
 - Ambient light
- View unfiltered or filtered data (class 1000, 600, 180, or 60)
- View data as absolute positions or relative to the position at the start of the data.

The 5th Female's data export screen (Figure 31) allows you to save RibEye Data with these options:

- Diadem, .CSV or .MME format
- Unfiltered or filtered (class 1000, 600, 180, or 60)
- Relative or absolute positions.

Note that in addition to exporting data downloaded from the RibEye, if you open an existing file on the data plotting screen, you can re-export the data in another format or with different options. In other words, data can be saved in multiple formats by exporting it several times.

However, we strongly recommend that you always save at least one copy of the absolute, unfiltered data for later analysis and quality checks.

Figure 29. Main software screen for Hybrid III 5th Female

The screenshot shows the main software screen for RibEye Ver 4.0. The interface includes several sections:

- Connect/Setup:** Contains tabs for 'Connect/Setup', 'Plot', 'Live Display', and 'Export'.
- RibEye Status:** A text box displays 'Connected - Idle'.
- Connection Info:** 'Connect to RibEye via:' is set to 'Ethernet' with an IP address of '192.168.0.152'. A 'DISCONNECT' button is present. A 'Find RibEyes' button is also available.
- Device Details:** 'RibEye Type:' is '5th Female', 'Serial Number:' is '00075', 'Calibration Date:' is '25 January 2010', and 'Firmware Version:' is '5BS002'.
- ATD Configuration:** 'RibEye Installed in ATD:' is 'HIII 5TH FEMALE' and 'Trigger Setting' is 'Rising Edge'.
- Test Object:** 'ISO Test Object' is '1 - Vehicle 1' and 'ISO Position' is '1 - Front Left'.
- Data Table:** A table titled 'Show Current XY's' displays data for 6 LEDs. Each row includes LED number, RIB number, POSITION, ISO CODES, X (mm), and Y (mm).
- Control Buttons:** 'ARM', 'ERASE MEMORY', and 'DOWNLOAD DATA' buttons are located at the bottom left.
- Data Collection Settings:** 'Data Buffer Operation' is set to 'Circular'. 'Data to collect after Trigger (ms)' is set to '2000'.
- Data in RibEye (ms):** 'Start Time' is '-500' and 'Stop Time' is '1500'.
- Data To Download (ms):** 'Start Time' is '-10' and 'Stop Time' is '400'.

LED	RIB	POSITION	ISO CODES	X (mm)	Y (mm)
1	1	LEFT	1 1 RIBS 01 LE HF DS X/Y	90.0	-50.0
2	2	LEFT	1 1 RIBS 02 LE HF DS X/Y	90.0	-50.0
3	3	LEFT	1 1 RIBS 03 LE HF DS X/Y	90.0	-50.0
4	4	LEFT	1 1 RIBS 04 LE HF DS X/Y	90.0	-50.0
5	5	LEFT	1 1 RIBS 05 LE HF DS X/Y	90.0	-50.0
6	6	LEFT	1 1 RIBS 06 LE HF DS X/Y	90.0	-50.0

© 2009 - 2016, Boxboro Systems LLC

Figure 30. Data plotting screen for Hybrid III 5th Female

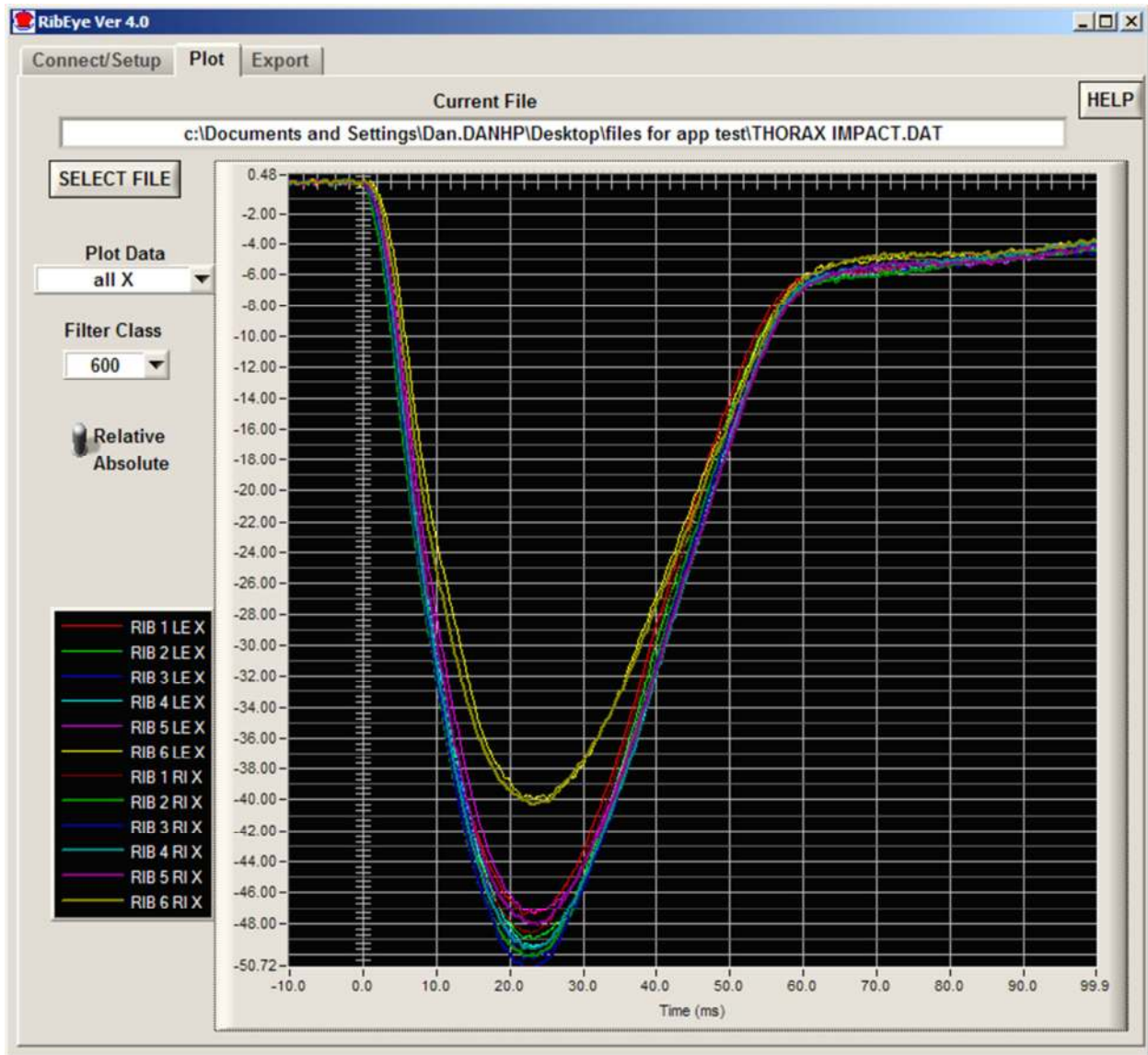
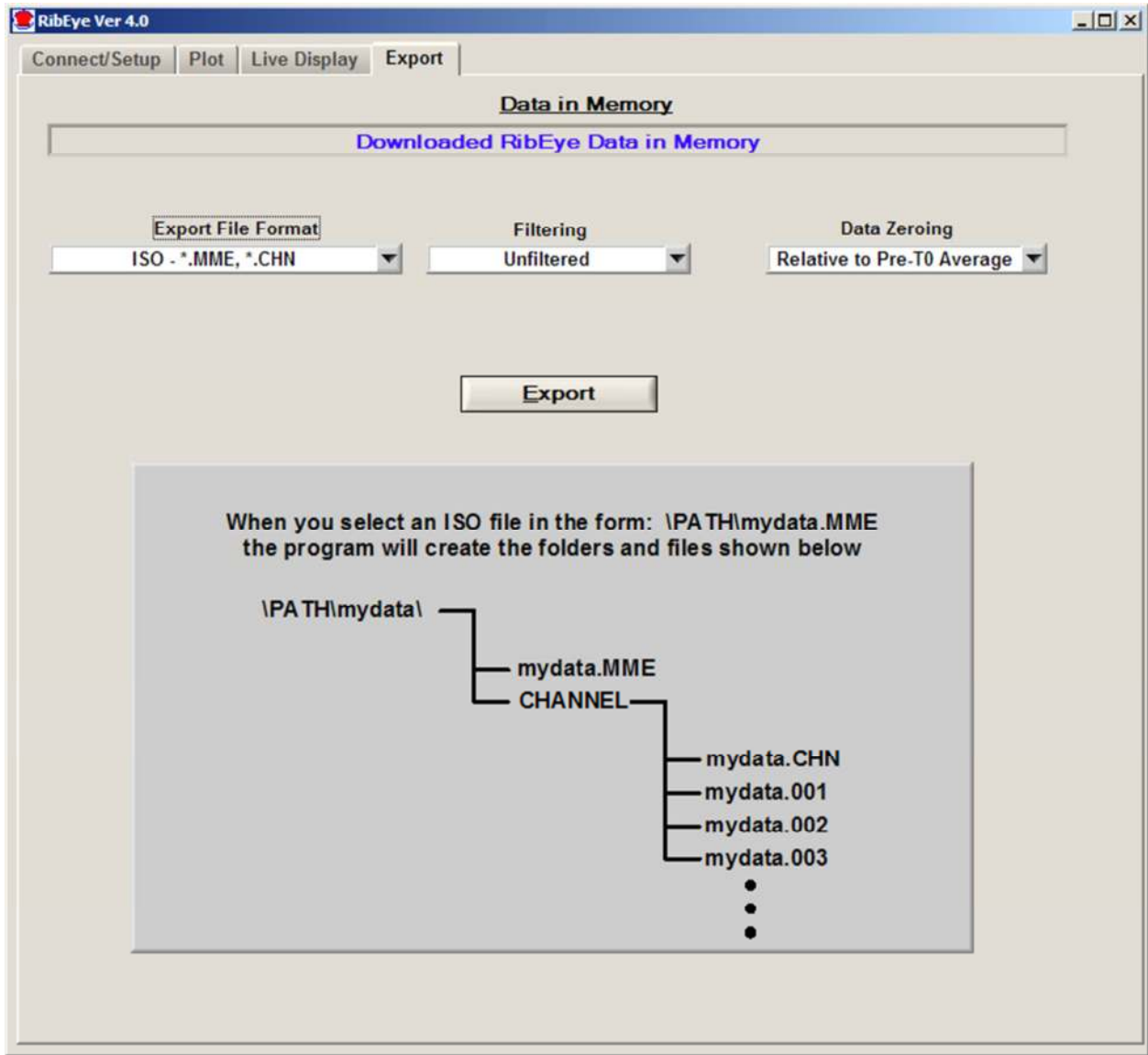

Figure 31. Data export screen for Hybrid III 5th Female
(Export File Format *.MME selected)



5.0 RibEye Maintenance

The RibEye lenses must be kept very clean for accurate measurements. Dust and smudges from fingers will affect the RibEye's accuracy detrimentally.

Follow this procedure for cleaning the lenses:

1. Blow the lenses off with canned compressed air (*not* shop air) to remove any grit
2. Wipe the lenses with a *dry*, clean, lint-free cloth, or wipe the lenses with a clean, lint-free cloth and lens-cleaning solution or alcohol

There are **NO** user-serviceable parts in the RibEye.

The interface/trunk box contains a polymer self-resetting fuse in the power line. If this fuse trips due to a cut cable or shorted cable, or if the incoming power cable is connected backwards, it can take 30 minutes for the fuse to cool down enough to reset after the short-circuit is removed.

Appendix A. RibEye specifications

A.1 Accuracy and measurement range

The RibEye's accuracy is specified in the calibration report that is shipped with each unit.

The accuracy of the RibEye depends on the Z (up and down) position of the ribs. The Hybrid III 5th Female has rib stops that limit the vertical motion of the ribs. Accuracy is checked with three Z offsets: zero (nominal rib position with no Z axis deflection), +/-10 mm, and +/-20 mm. Table A1 lists the maximum error specifications over the range of these three Z offsets.

Table A1. Maximum error specifications over the range of Z offsets

Z offset from nominal position	Maximum X error	Maximum Y error
mm		
0	1	1
+/-10	1	1
+/-20	1.25	1.5

The measurement range and typical accuracy of the RibEye in the X-Y plane are shown in Figures A1 and A2 for Rib 1. This data is from a calibration report.

Figure A1. RibEye measurement range and typical accuracy, Rib 1 X axis (calibration report data)

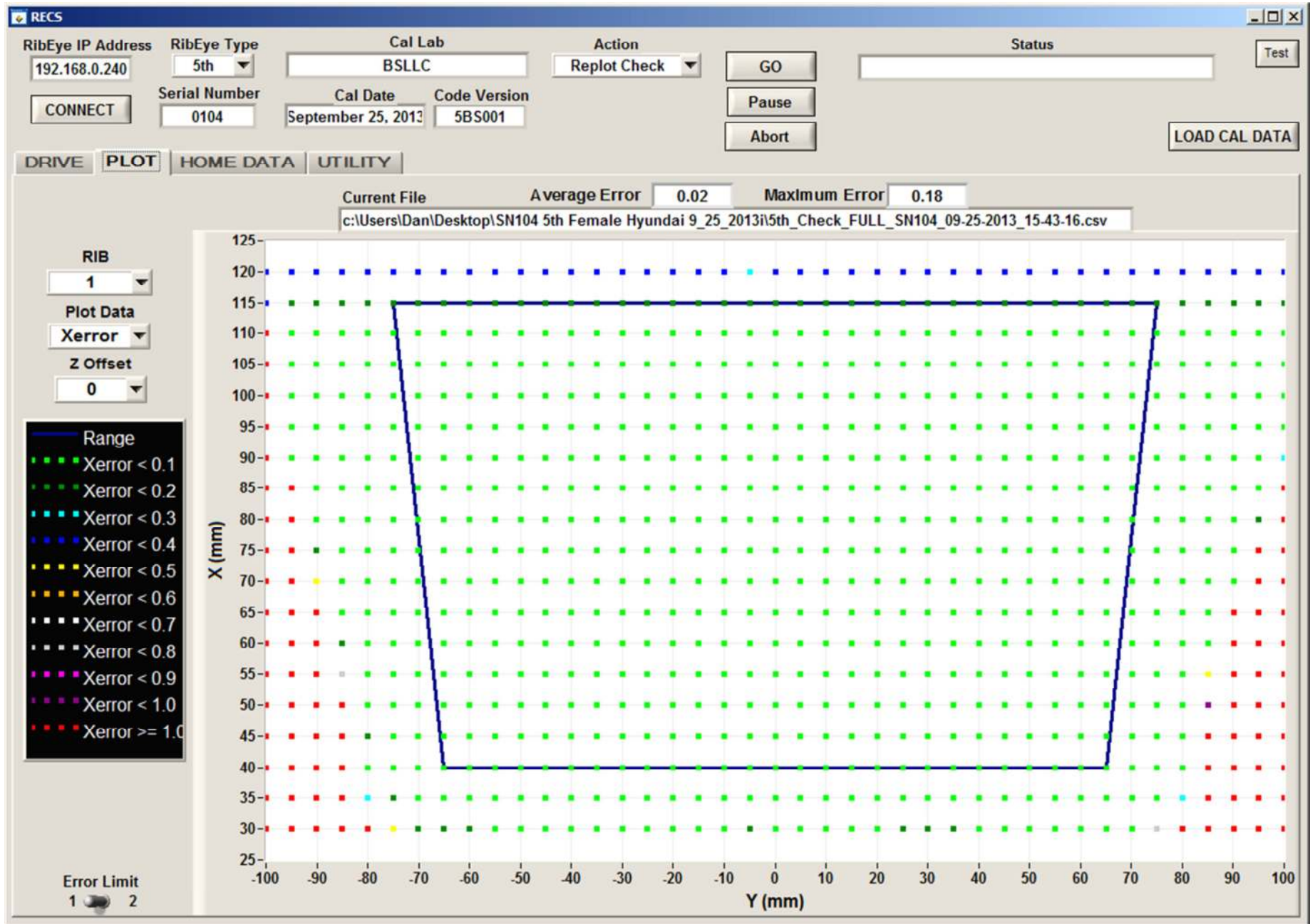

Figure A2. RibEye measurement range and typical accuracy, Rib 1 Y axis (calibration report data)

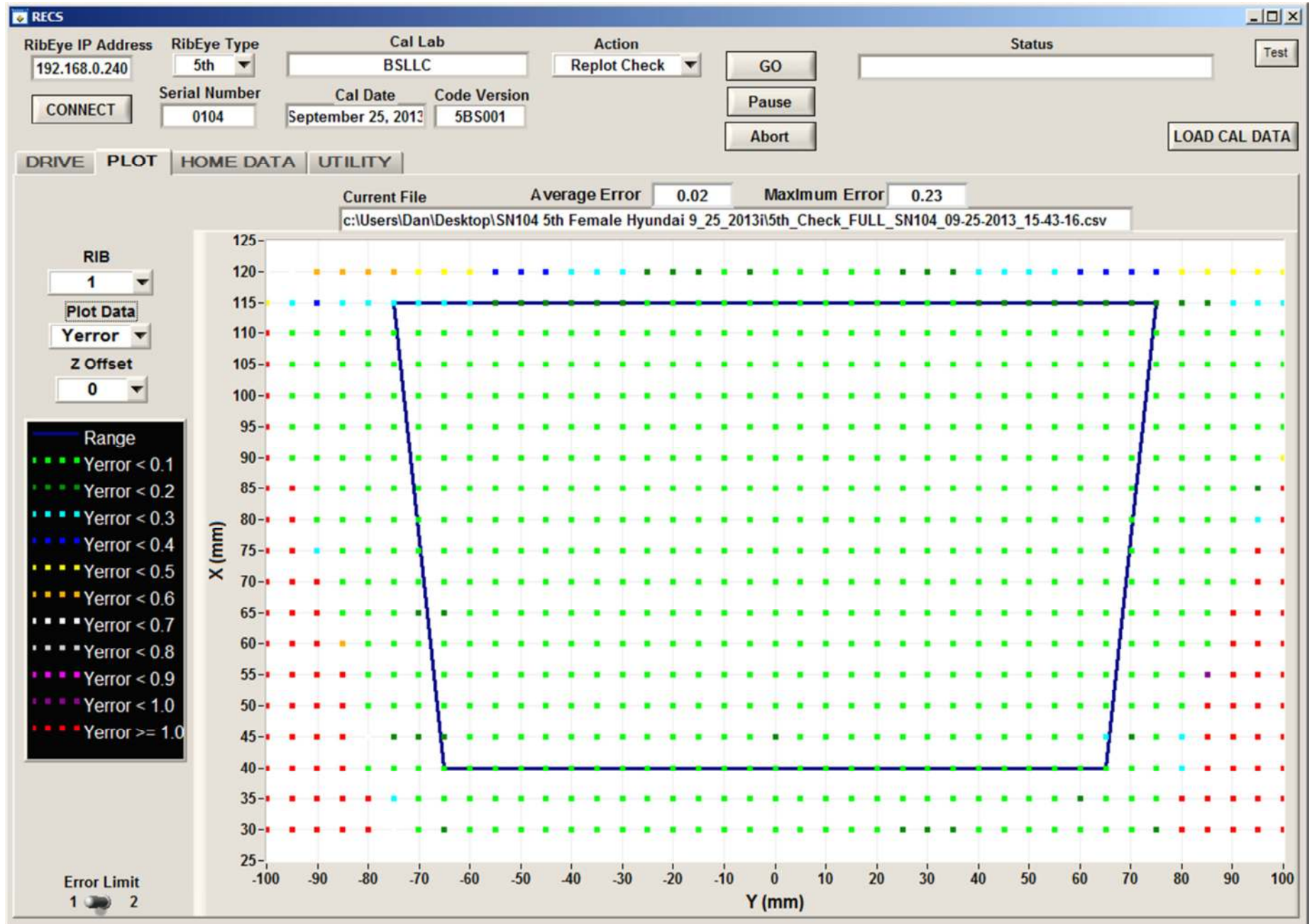

Table A2 shows the accuracies measured over the entire range for each rib at a Z offset of zero. Tables A3–A6 show accuracy data for Z offsets of ± 10 mm and ± 20 mm. All of this data is from a calibration report.

Table A2. RibEye accuracy data (zero Z offset)

Rib number	X error		Y error	
	mm			
	Max.	Avg.	Max.	Avg.
1 (top)	0.08	0.02	0.23	0.02
2	0.12	0.02	0.08	0.01
3	0.39	0.03	0.29	0.02
4	0.36	0.03	0.30	0.02
5	0.19	0.02	0.14	0.01
6 (bottom)	0.09	0.01	0.05	0.01

**Table A3. RibEye accuracy data
(Z offset of -10 mm)**

Rib number	X error		Y error	
	mm			
	Max.	Avg.	Max.	Avg.
1 (top)	0.39	0.16	0.64	0.27
2	0.38	0.15	0.60	0.26
3	0.46	0.15	0.48	0.22
4	0.35	0.17	0.22	0.11
5	0.35	0.15	0.20	0.06
6 (bottom)	0.44	0.21	0.25	0.10

**Table A4. RibEye accuracy data
(Z offset of $+10$ mm)**

Rib number	X error		Y error	
	mm			
	Max.	Avg.	Max.	Avg.
1 (top)	0.46	0.17	0.70	0.25
2	0.45	0.18	0.61	0.22
3	0.37	0.17	0.55	0.15
4	0.41	0.19	0.43	0.06
5	0.48	0.23	0.25	0.09
6 (bottom)	0.47	0.28	0.29	0.13

**Table A5. RibEye accuracy data
(Z offset of -20 mm)**

Rib number	X error		Y error	
	mm			
	Max.	Avg.	Max.	Avg.
1 (top)	0.78	0.32	1.30	0.53
2	0.74	0.31	1.21	0.51
3	0.73	0.29	1.00	0.43
4	0.63	0.33	0.55	0.23
5	0.51	0.31	0.29	0.11
6 (bottom)	0.77	0.42	0.45	0.18

**Table A6. RibEye accuracy data
(Z offset of +20 mm)**

Rib number	X error		Y error	
	mm			
	Max.	Avg.	Max.	Avg.
1 (top)	0.85	0.33	1.23	0.51
2	0.80	0.31	1.16	0.44
3	0.77	0.36	0.82	0.26
4	0.57	0.37	0.48	0.11
5	0.81	0.47	0.47	0.18
6 (bottom)	0.92	0.55	0.55	0.25

A.2 Power requirements

The RibEye can be powered by any DC power source from 12 to 36 Volts. The power cable from the RibEye's interface/trunk box to the power source has two conductors: the red wire is positive, and the black wire is negative (ground). Appendix B.2 provides more information on the power input cable. The trunk box has an internal self-resetting polymer fuse. It can take up to 30 minutes to reset after an overload.

The RibEye's power draw depends on the status of its operating condition, as shown in Table A7.

Table A7. RibEye power requirements

Operating Condition	Trunk Box	Controller + LEDs	Total
	Watts		
On/idling	3.3	2	5.3
Acquiring data (typical)	3.3	5	8.3
Maximum*	3.3	9	12.3

* When all LEDs are out of view of both sensors and driven to full power.

A.3 Data acquisition and storage

Data is collected to RAM memory and stored post-test in flash memory.

Sample rate: 10,000 samples per second per LED

Acquisition time: 30,000 ms (30 seconds) in RAM, 2 seconds in flash memory

A.4 RibEye coordinate system

RibEye X axis is parallel to the ribs – see Figure A3.

RibEye Z axis is perpendicular to the ribs – see Figures A3 and A4.

RibEye Y axis is parallel to the dummy Y axis – see Figure A4. The RibEye Y axis passes through points at the centers of the optical slits on the sensor heads, 2 mm behind the front face of the lens.

The dummy X and Z axes are defined by the top and back of spine – see Figure A3.

RibEye X-Z plane is rotated from the dummy X-Z plane by 4.5 degrees.

Figure A3. RibEye and Dummy X and Z axes

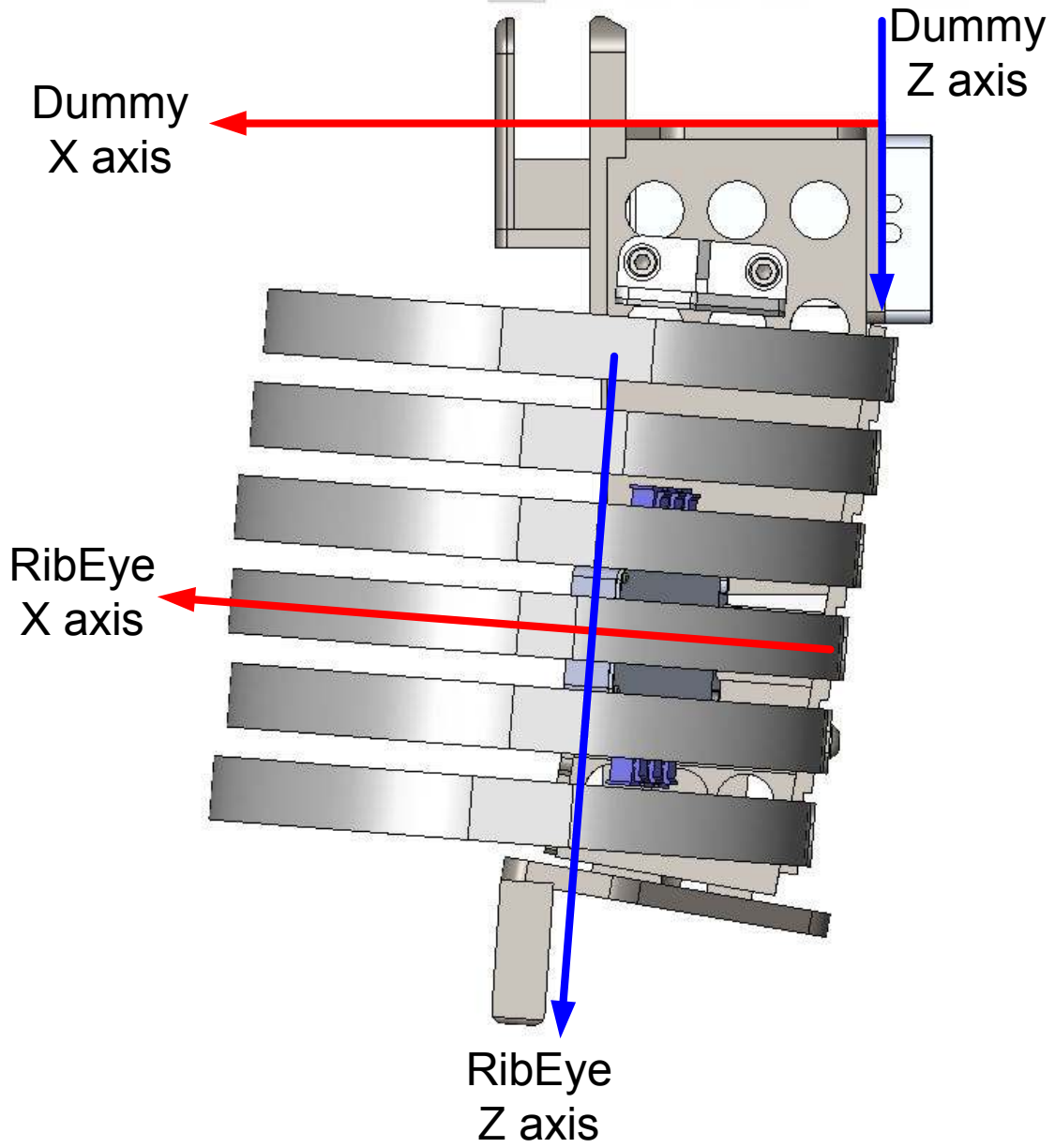
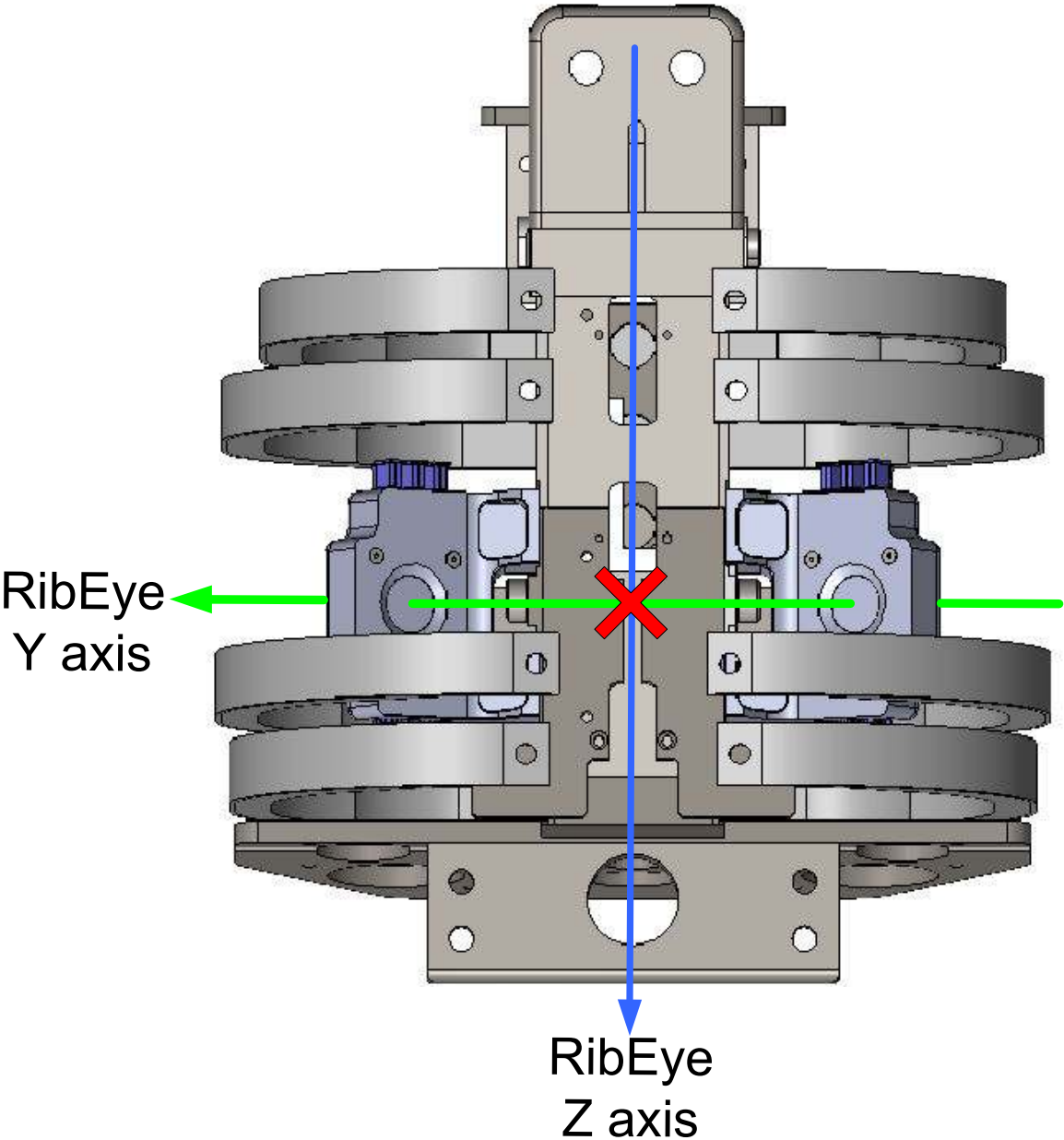

Figure A4. RibEye Y and Z axes



Appendix B. Cable assemblies

The RibEye is provided with the following cables:

- Controller cable that connects from the trunk box to the RibEye controller
- Power-in cable from the trunk box to an external power source
- Trigger cable for connecting to a trigger source and providing an armed output signal
- LED cables (12), numbered to correspond to the dummy ribs

All push-pull connectors are Lemo connectors with solder cup connections.

All Molex Microfit 3.0 connectors are crimp types. The drawings call out the crimp terminals used. We recommend using a Molex crimp tool designed for the Microfit 3 series. The current production hand crimp tool is Molex part number 638190000.

B.1 Controller cable

Figure B1 shows the controller cable that plugs into the interface/trunk box and the connector that plugs into the RibEye controller. Figures B2 and B3 provide details on the connector and wiring at both ends of the controller cable.

Figure B1. RibEye controller cable and connector

A = Lemo end; B = Microfit end (connector)

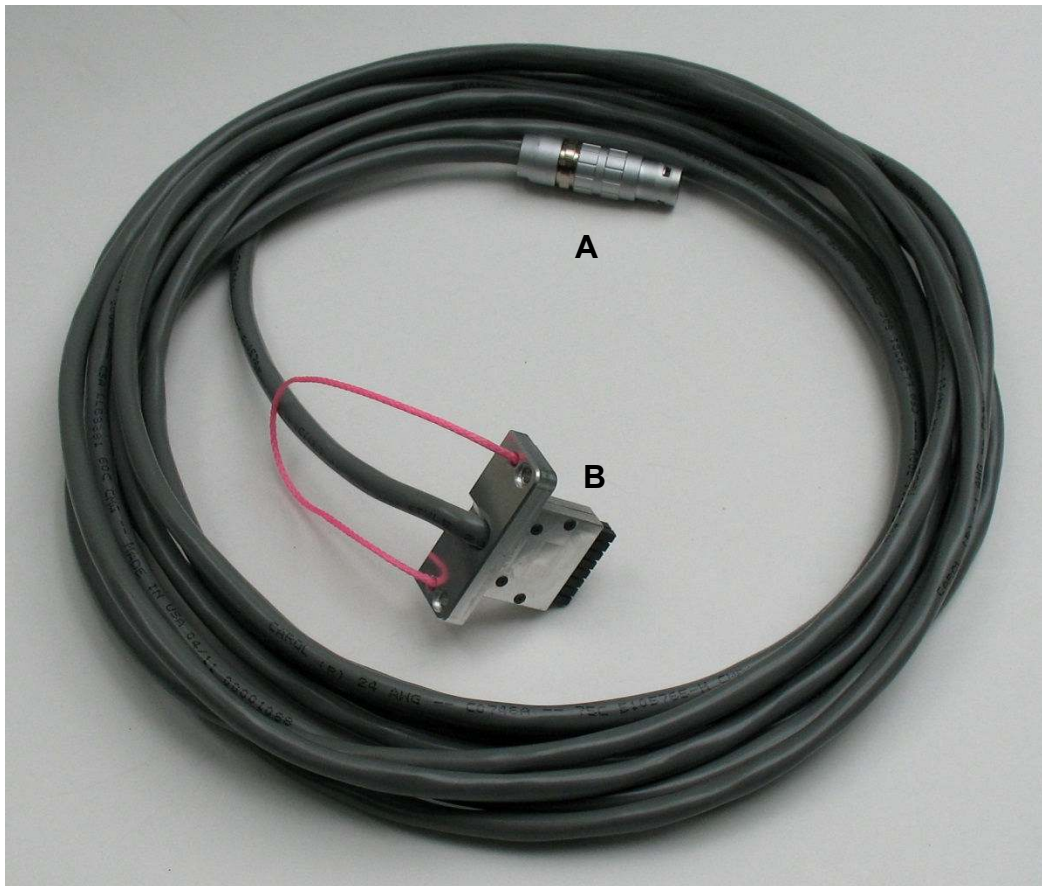
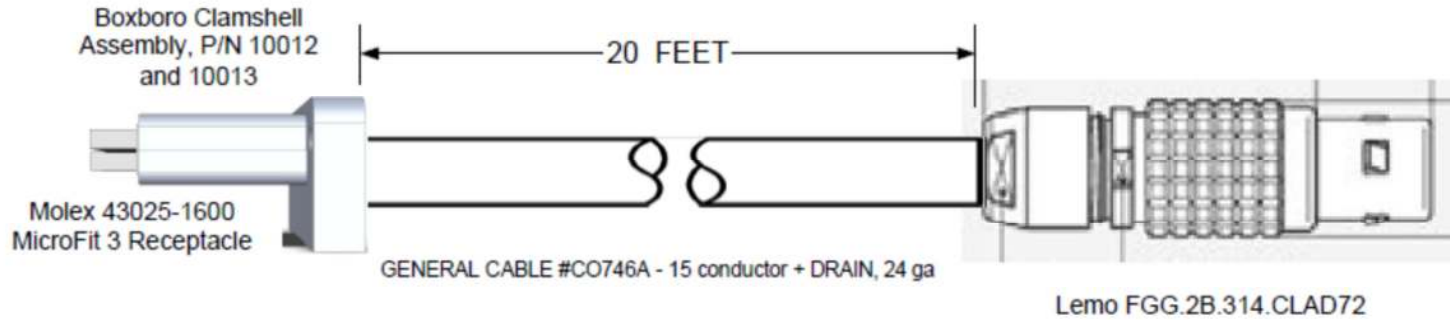
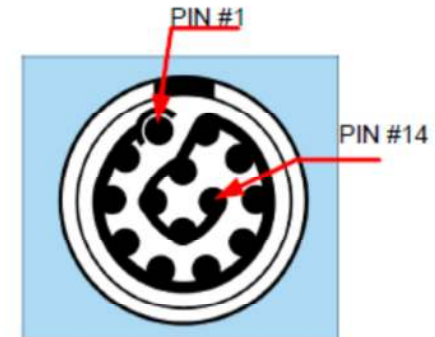

Figure B2. Controller cable, Lemo connector end details



USE 1/4 INCH LENGTH OF 1/16" HEATSHRINK OVER ALL PINS

Wire Color in cable Gen Cable C0746A	MicroFit Pin Number	Lemo Pin Number	SIGNAL NAME
Drain	X	BACKSHELL	SHLD
WHITE	10	1	STATUS OUT
GREEN	14	2	OTHER IN
ORANGE	3	3	TRIG+
BLUE	13	4	TRIG -
WHITE/BLACK	2	5	CTRL COMM
Red	16	6	PWR+
Red/White	8	7	PWR+
RED/BLACK	1	8	ARMOUT
ORANGE/BLACK	11	9	RX
BLUE/BLACK	12	10	TX
GREEN/WHITE	6	11	CTS
BLUE/WHITE	5	12	RTS
Black	15	13	PWR -
Black/White	7	14	PWR -
GREEN/BLACK	n/c	n/c	TRIGOUT



View of wire side of insert

BOXBORO SYSTEMS LLC 369 Sargent Road, Boxborough, MA 01719 978-257-2219		
Part # 40013		
Rev 0	1/19/2016	sheet 1 of 2
Power/Comm Cable Assembly Lemo End Details		

Figure B3. Controller cable, Microfit end details

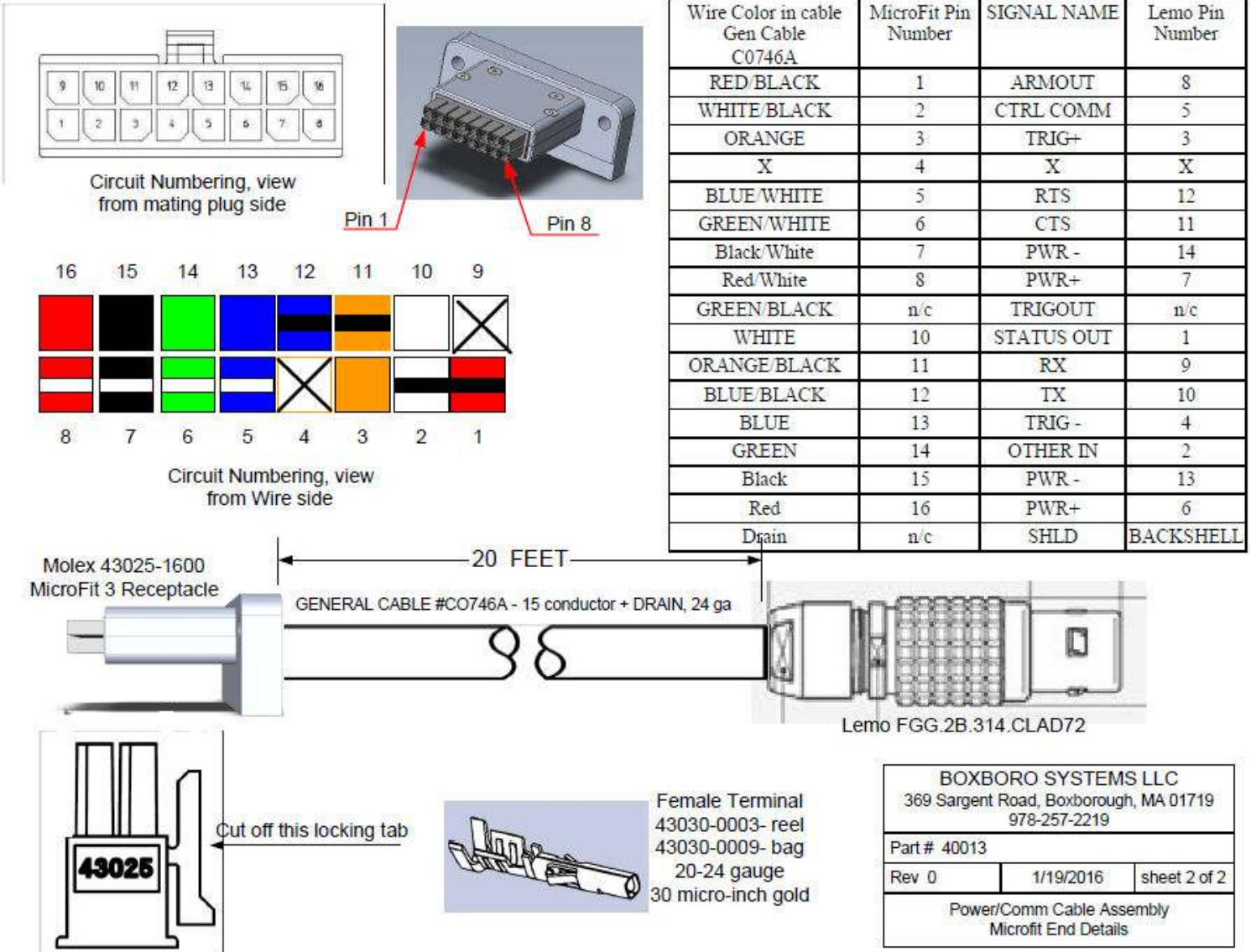

B.2 Power input cable

The power input cable from the RibEye's interface/trunk box to the power source is terminated at the user end in pigtails. The power cable has two conductors: the red wire (positive) and the black wire (negative/ground), as noted in Appendix A.2, Power requirements. The red wire is connected to the DC power source's positive power connection. The black wire is for the DC power source's negative (ground) connection. Figures B4 and B5 show the power-in cable and the wiring details.

Figure B4. Power cable from RibEye trunk box



Figure B5. Power cable details

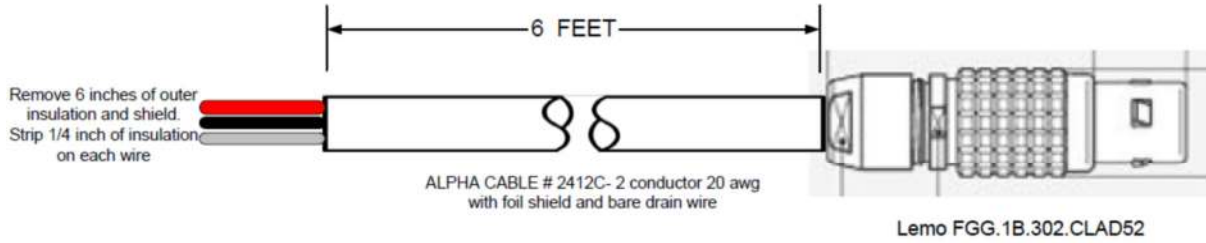

USE 1/4 INCH LENGTH OF 1/16" HEATSHRINK OVER ALL PINS

Wire Color	Lemo Pin Number
Red	1
Black	2
Drain	Body

View of wire side of insert

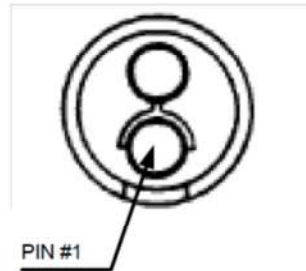

BOXBORO SYSTEMS LLC 369 Sargent Road, Boxborough, MA 01719 978-257-2219		
Part # 40011		
Rev 1	3/1/2016	sheet 1 of 1
Power In Cable Assembly		

B.3 Trigger cable

Figures B6 and B7 show the RibEye's trigger cable and details. Appendix C contains more detailed information on the trigger and armed output signals, including wiring options.

Figure B6. Trigger cable from RibEye trunk box



Figure B7. Trigger cable details

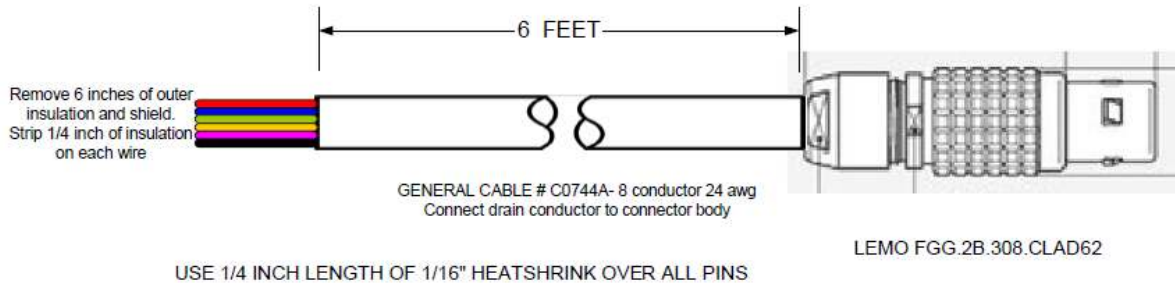

Wire Color General Cable C0744A	Lemo Pin Number	Signal
RED	1	3.3V PULL-UP
WHITE	2	LO I TRIGGER IN +
GREEN	3	LO I TRIGGER IN -
ORANGE	4	V+ PULL-UP
BROWN	5	HI I TRIGGER IN +
BLACK	6	GROUND
YELLOW	7	ARMOUT +
BLUE	8	ARMOUT-
Drain	Connector body	

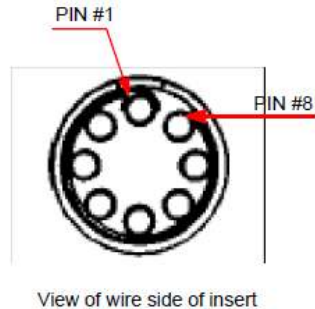

BOXBORO SYSTEMS LLC 369 Sargent Road, Boxborough, MA 01719 978-257-2219		
Part # 40012		
Rev 0	1/19/2016	sheet 1 of 1
Trigger Cable		

B.4 LED cables

Figures B8 and B9 show the RibEye LED cable assemblies. The cable is soldered onto the LED assembly (Figure B10). The LED assembly consists of the LED mounted to a Metal Clad Printed Circuit Board (MCPCB) that acts as a heat sink. Figure B11 shows the details of the LED cable’s Microfit plug end.

DANGER: *If you need to re-solder a LED assembly to a new cable, note that the MCPCB will get very hot. You must do the soldering work on a thermal insulator and be aware that the MCPCB will be at the same temperature as the melted solder. Make sure that you do not touch the MCPCB when soldering.*

Replacement LEDs with cables are available from Boxboro Systems. The connector on the LED assemblies (Figure B10) is easily replaceable.

Figure B8. LED cables (lead wires) attached to connector blocks in RibEye sensor heads (rear spine view)



Figure B9. LED cables, connector blocks, and sensor heads (front spine view)

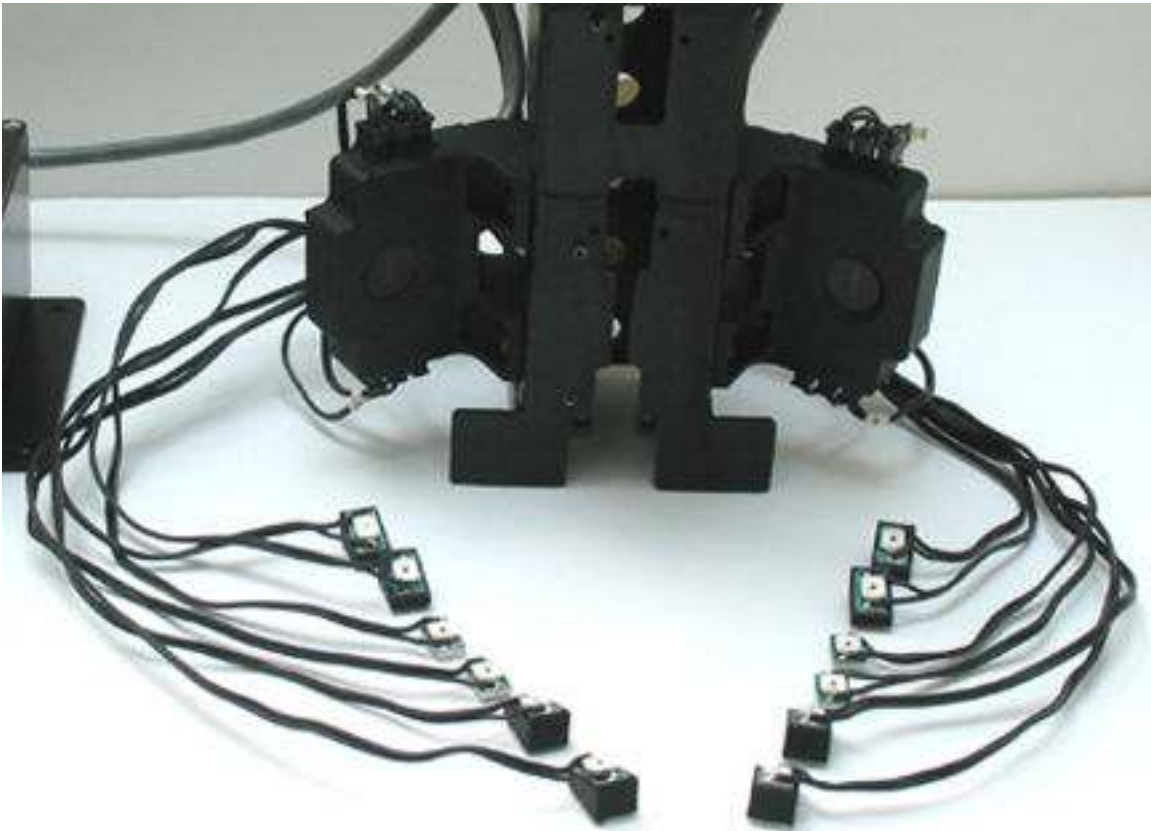

Figure B10. LED cable soldered to LED assembly

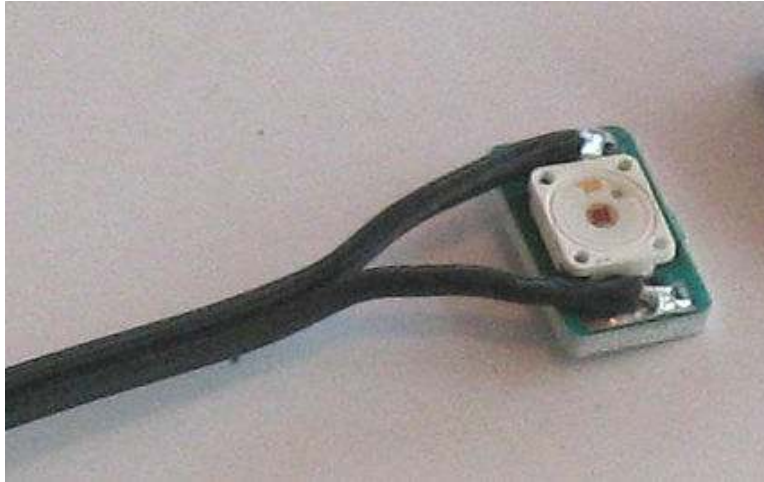
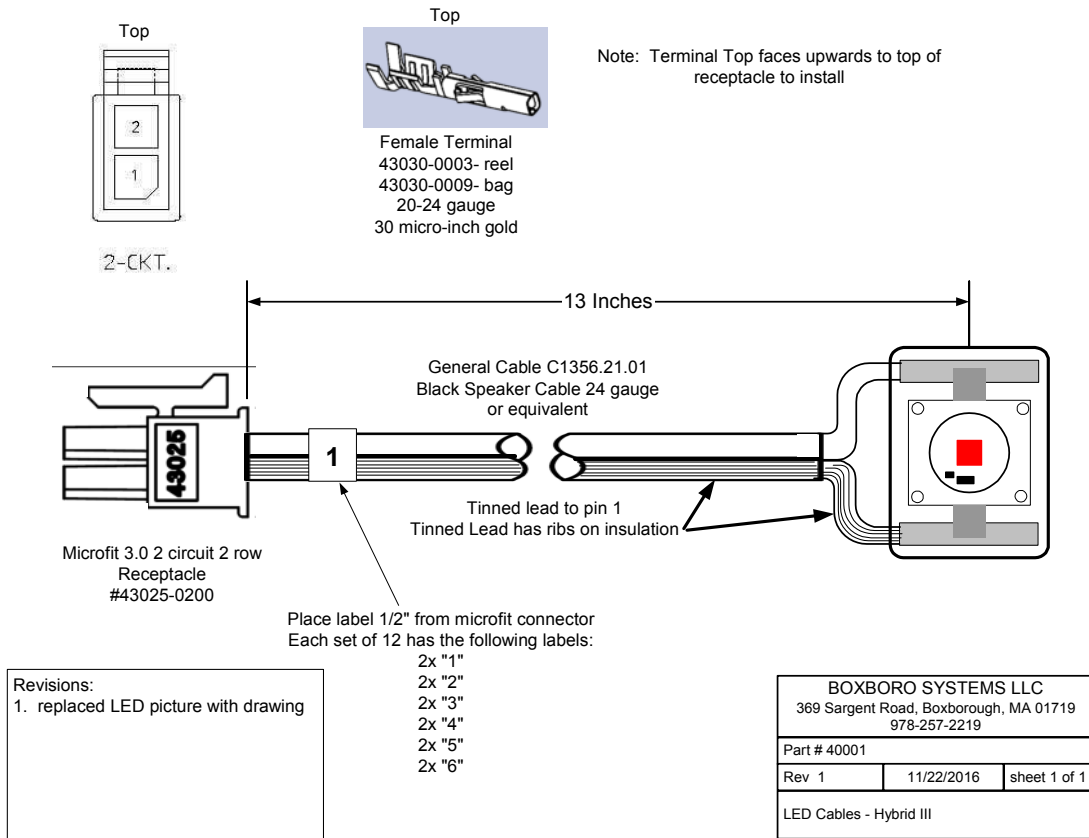

Figure B11. LED cable, Microfit end details



B.5 Cable assemblies for connecting to DAS

Boxboro Systems can provide cable assemblies for connecting to data acquisition systems (Figure B12):

- For a DTS Mini-Distributor (MDB), order cable Part #40500, which plugs into one of the four system ports on the MDB. At the other end are plugs for power, trigger, and Ethernet.
- For a Kistler KiDAU system, order cable Part #40510, which plugs into the interface-out jack on the last KiDAU module in the chain. At the other end are plugs for power, trigger, and Ethernet.

Figure B12. Cable assemblies for connecting RibEye to data acquisition systems

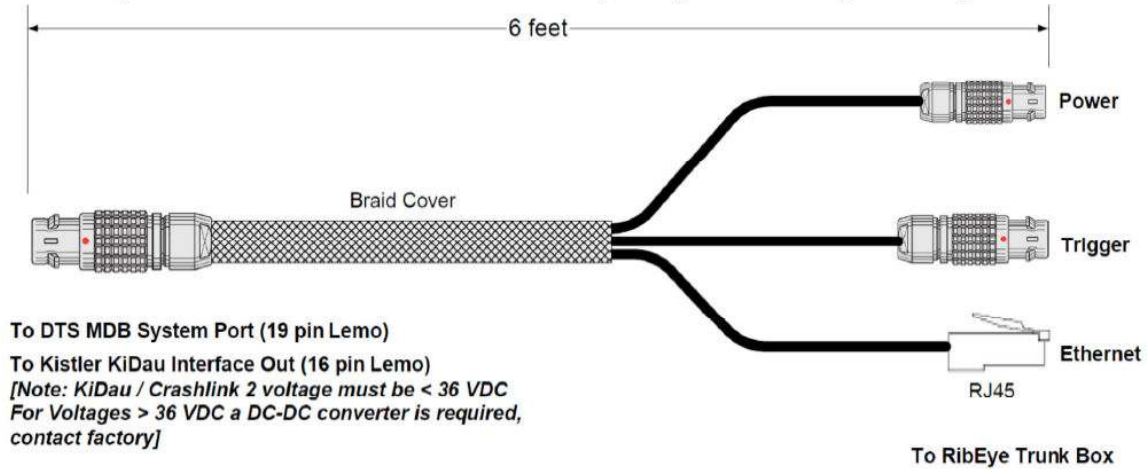

Appendix C. Trigger inputs and armed output circuits

The trigger interface connector on the RibEye's trunk box is an 8-pin Lemo connector. A mating cable, terminated in a pigtail, is supplied with the RibEye (Figure B6 above). Table C1 lists the pigtail color codes, pin numbers, and signal functions. Figure C1 shows a partial schematic of the interface.

Table C1. Trigger cable signals

Wire Color (General Cable C0744A)	Lemo Pin Number	Signal
RED	1	3.3V PULL-UP
WHITE	2	Low Impedance (Opto) TRIGGER IN +
GREEN	3	Low Impedance (Opto) TRIGGER IN –
ORANGE	4*	Power Supply Voltage PULL-UP
BROWN	5*	High Impedance (FET) TRIGGER IN +
BLACK	6	GROUND
YELLOW	7	ARMOUT +
BLUE	8	ARMOUT –

* Older model trunk boxes have no connections on pins 4 and 5. If a voltmeter connected between pins 4 and 6 does not show the power supply voltage, the trunk box is an older model.

The low impedance trigger input uses an optical isolator and can be used with tape switches, Kistler CrashLink RS485 type or TTL trigger circuits, or an airbag fire circuit with a suitable load resistor.

The high impedance trigger input uses an FET transistor circuit and can be used with high impedance trigger systems such as the port trigger from a DTS TDAS Pro MDB. If the high impedance trigger input (brown wire) is not being used, it should be connected to ground (black wire) to prevent accidental triggering from noise.

Maximum Ratings:

Trigger Input from Trigger In + to Trigger In – = 25 Volts-DC (15 Volts for older models)
 High impedance (FET) Trigger In + = 15 Volts-DC
 Armed Output from Armout + to Armout – = 10 Volts-DC

Note that the opto trigger input and armed output are fully isolated. Figures C2–C7 show typical connection diagrams.

Figure C1. Partial interface schematic

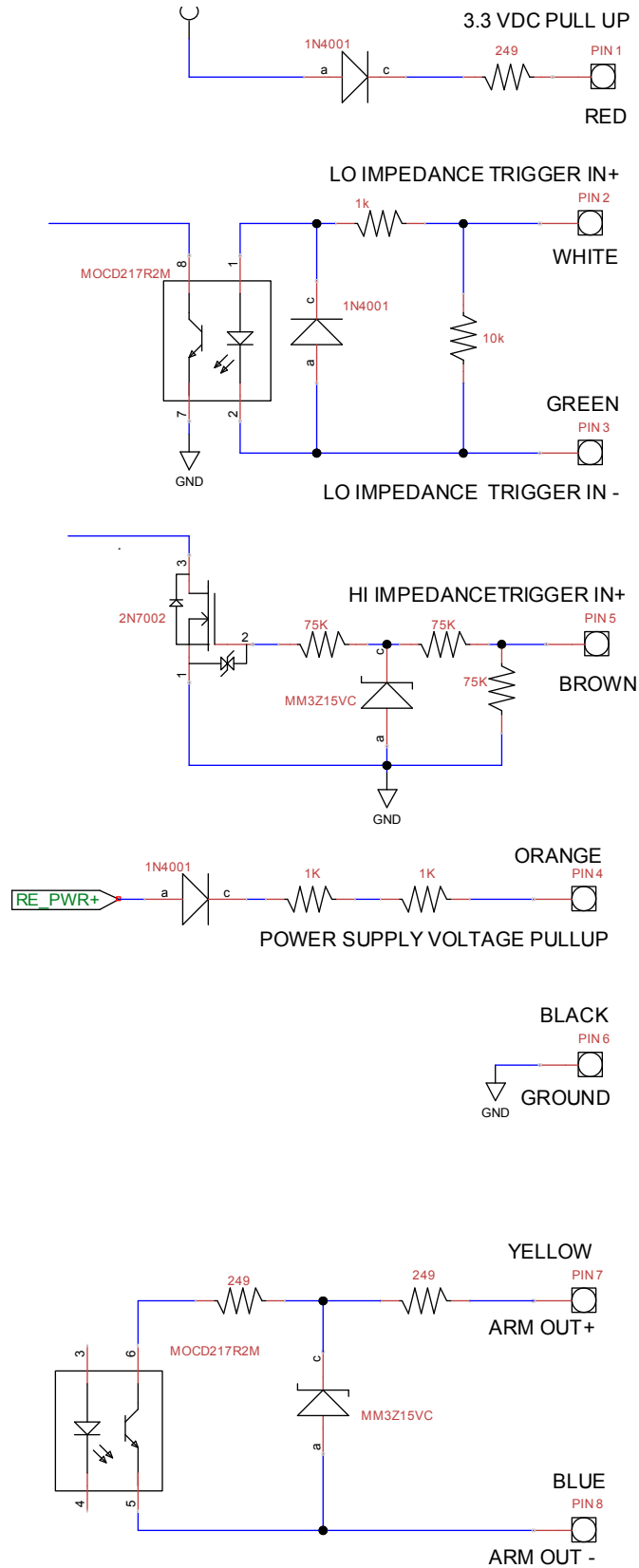
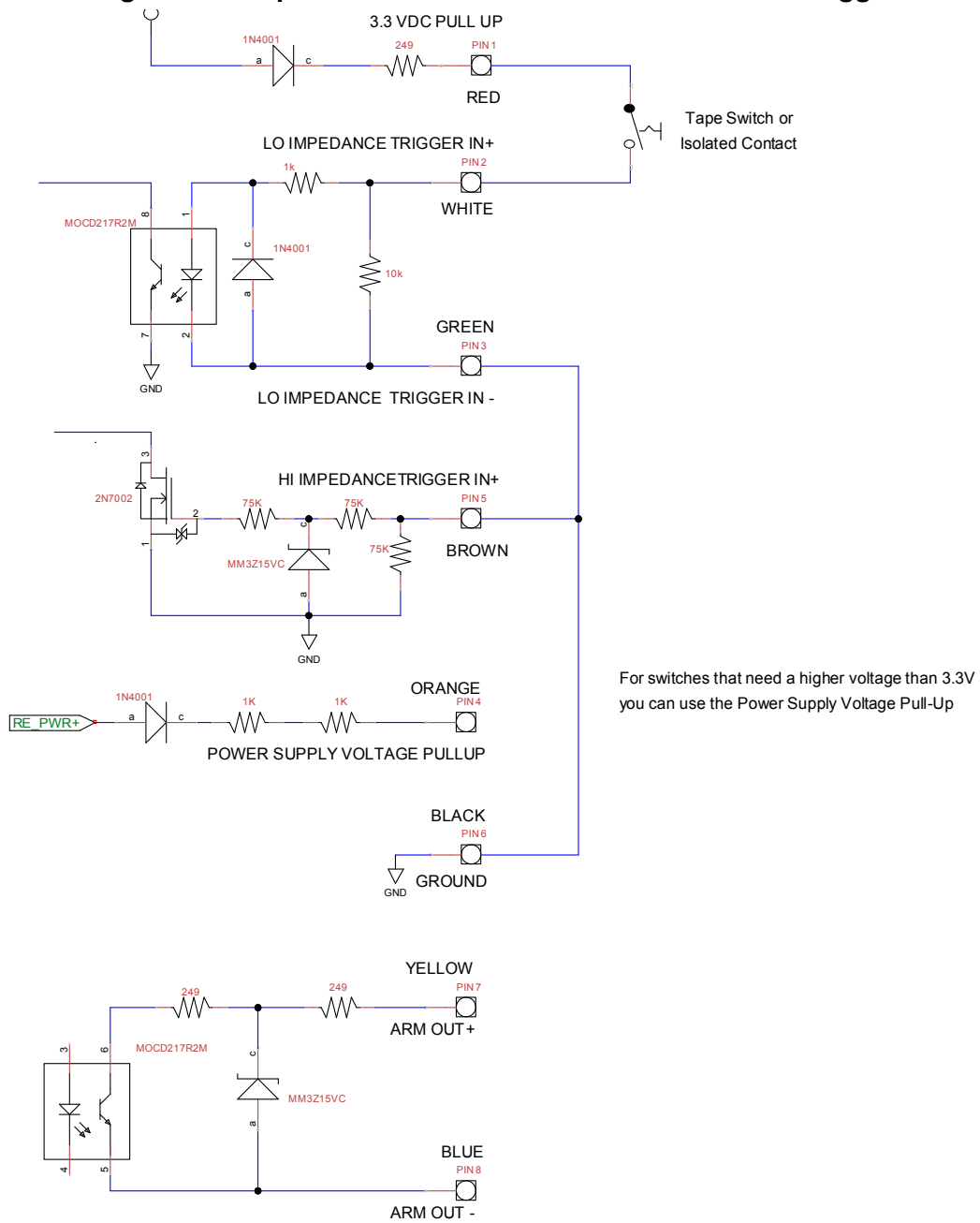

Figure C2. Tape switch or isolated contact closure for trigger



For this connection switch connection option:

If the switch *closes* at the start of the event, select RISING EDGE on the RibEye software trigger setting.

If the switch *opens* at the start of the event, select FALLING EDGE on the RibEye software trigger setting.

For more information, please refer to the RibEye Software User Manual, section 2.3, Trigger Setting.

Figure C3. Alternative tape switch or isolated contact closure for trigger

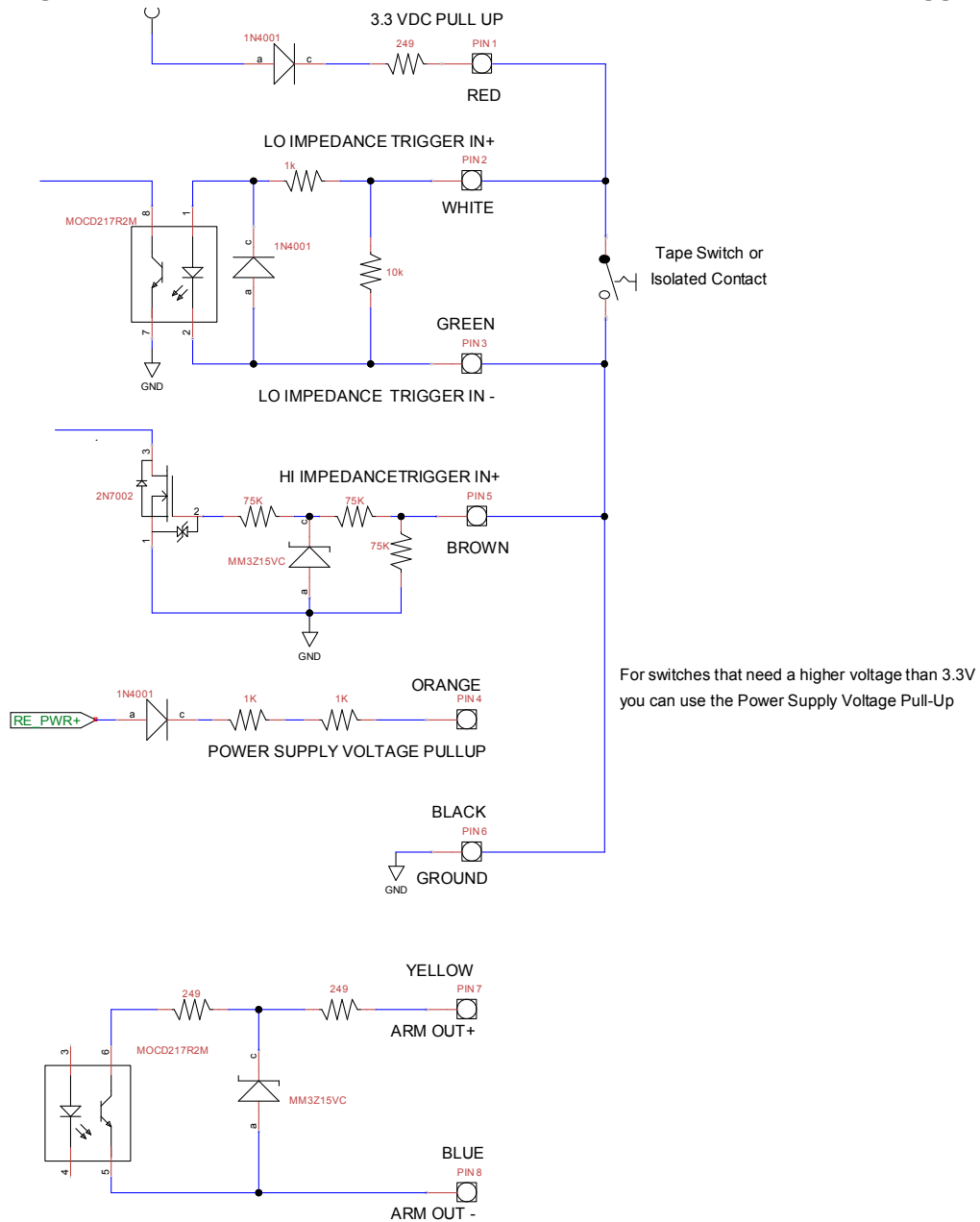

For this connection switch connection option:

If the switch *closes* at the start of the event, select FALLING EDGE on the RibEye software trigger setting.

If the switch *opens* at the start of the event, select RISING EDGE on the RibEye software trigger setting.

Figure C4. Active trigger source

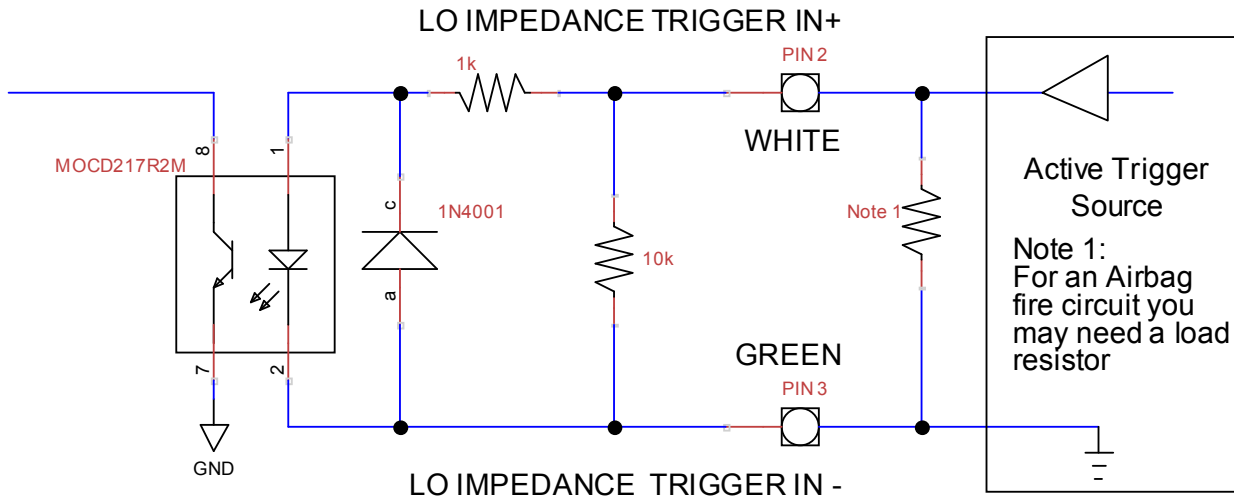

Figure C5. Differential trigger source

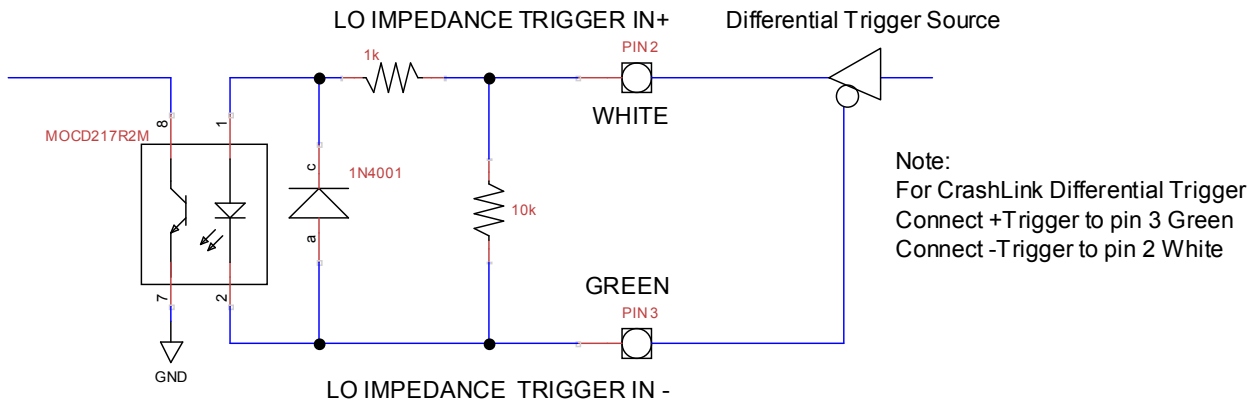

Figure C6. DTS MDB trigger source

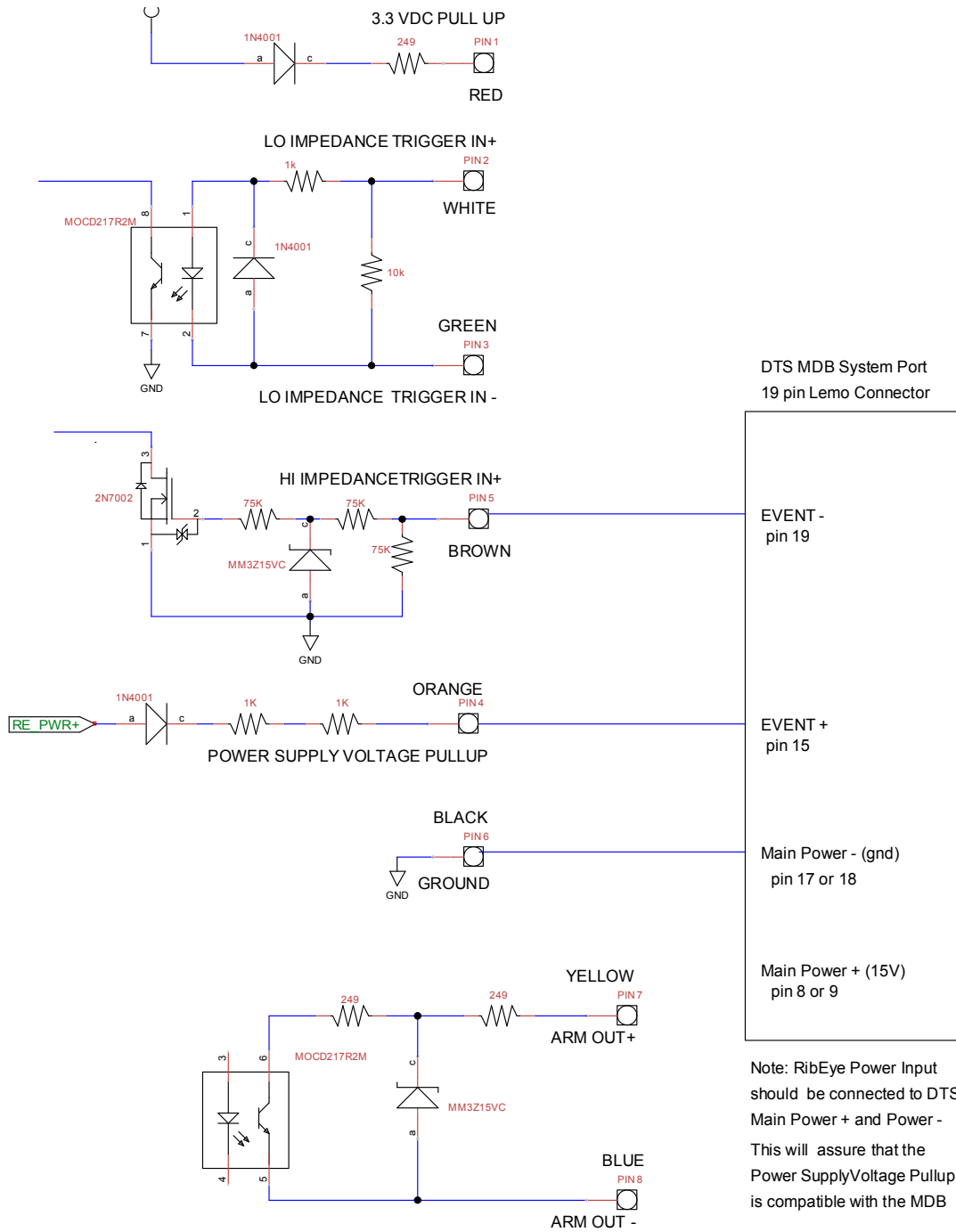
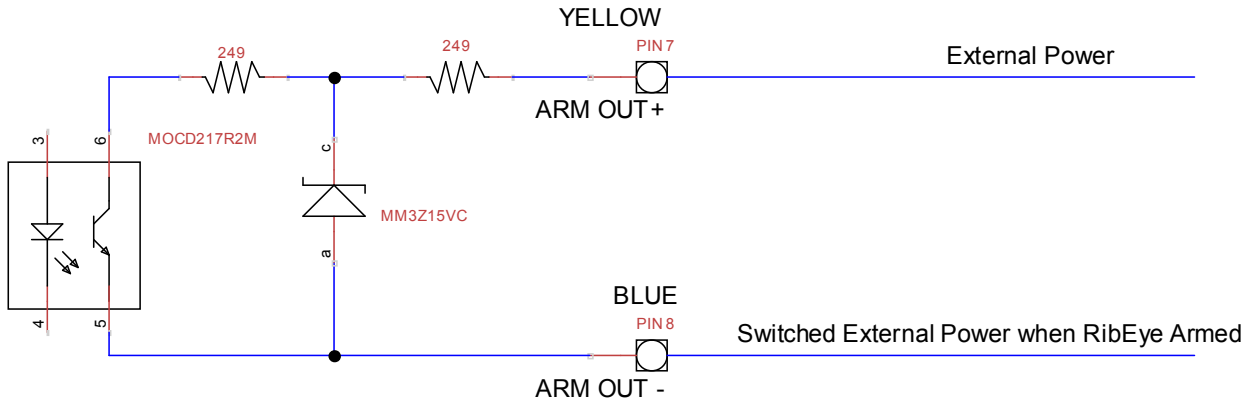

Figure C7. Armed output connection



The armed output can be used to signal other equipment that the RibEye is armed. To maintain isolation, the circuit shown above is configured as an emitter follower, with the collector of the output transistor connected to the external logic power source. The transistor emitter will switch when the RibEye is armed.